



Electric Line Clearance Management Plan 2018/2019

Prepared by: Strathbogie Shire Council
March 2018

Applicable to the Declared Areas for the townships of:

Avenel and Euroa

Project Officer:	Mark Gordon			
Computer File:	I:\Infrastructuresolutions\IS13105.04_Sos-Electriclineclearanceplan\Reports\IS13105.04_Strathbogie-ELCVMP1415-Ver5.Docx			
Last Saved:	March 2018			
Issued To	Transmission Type	Qty.	Date	Authorised
Bruce Braines Executive Manager Assets	PDF & DOC	1	31/03/2016	Director Asset Services
Mark Gordon Project Officer	PDF & DOC	1	31/03/2016	Direct Asset Services
Bruce Braines Manager Assets	DOC	1	22/08/2017	Manager Assets

Disclaimer

This Electric Line Clearance Management Plan ('Plan or ELCMP') has been developed by the Strathbogie Shire Council to inform Strathbogie Shire Council (Council), Energy Distribution Businesses (DB's) and all other interested parties about the vegetation management processes and strategies undertaken by the Strathbogie Shire Council to care for its trees that are in the vicinity electricity assets. This Plan is to satisfy the requirements of the Electricity Safety (Electric Line Clearance) Regulations 2015 (Vic).

Strathbogie Shire Council notifies users of this Plan that some of the content/statements made in this Plan are based on assumptions, estimates, predictions and projections made as part of the Strathbogie Shire Council's Tree Management planning/development process and some of the content/statements are based on actions that the Strathbogie Shire Council intends to take in the future. The Strathbogie Shire Council may decide to take different actions to those it currently intends to take if circumstances change or assumptions and estimates prove to be inaccurate and events do not occur as predicted or projected. The users of this Plan accept responsibility and all risk for using material in this document. The users should seek expert advice in relation to their own circumstances and must rely solely on their own judgement and expert advice obtained.

The Strathbogie Shire Council including its Panel Consultants does not guarantee and will not be liable for, whether in contract, tort (including negligence), equity or otherwise, to compensate or indemnify any person for any loss, injury or damage arising directly or indirectly from any person using, or relying on any content/statements in this Plan.

March 2017

Plan Term:

This plan covers the period 2015-2020 in line with the revision period for the regulations. Each year this plan will be revised and updated as required. Annual revisions will be reviewed by Council's Manager Assets and its Project Officer. Updates and revisions will be recorded in the document version table.

TABLE OF CONTENTS

9(2)	4
9(3) (a)	Name, address and telephone number of the responsible person:.....	4
9(3) (b)	Name, position, address and telephone number of the individual who was responsible for the preparation of the management plan:.....	4
9(3) (c)	Name, position, address and telephone number of the persons who are responsible for carrying out the management plan:	5
9(3) (d)	The telephone number of a person who can be contacted in an emergency that requires clearance of an electric line that the responsible person is required to keep clear of trees:	5
9(3) (e)	The objectives of the management plan:.....	5
9(3) (f)	The land to which the management plan applies (as indicated on a map)	6
9(3) (g)	The location of each area that the responsible person knows contains a tree that the responsible person may need to cut or remove to ensure compliance with the code and that is:.....	7
9(3) (h)	The means which the responsible person is required to use to identify a tree of a kind specified in paragraph (g)	8
9(3) (i)	The management procedures that the responsible person is required to adopt to ensure compliance with the Code, which must:	9
9(3) (j)	The procedures to be adopted if it is not practicable to comply with the requirements of AS4373 while cutting a tree in accordance with the code;	14
9(3) (k)	A description of each alternative compliance mechanism in respect of which the responsible person has applied, or proposes to apply, for approval under clause 31 of the code;	15
9(3) (l)	The details of each approval for an alternative compliance mechanism that:.....	15
9(3) (m)	A description of the measures that must be used to assess the performance of the responsible person under the management plan;.....	15
9(3) (n)	Details of the audit process that must be used to determine the responsible person's compliance with the Code;	15
9(3) (o)	The qualifications and experience that the responsible person must require of the persons who are to carry out the inspection, cutting or removal of trees in accordance with the Code;	17
9(3) (p)	Notification and consultation procedures, including the form of the notice to be given in accordance with Division 3 of Part 2 of the Code;	18
9(3) (q)	Dispute resolution procedures;	20
9(4)	A method for determining and additional distance that allows for cable sag and sway may provide for different additional distances to be determined for different parts of a span of an electric line;	20
10(7)	The responsible must ensure that a copy of the management plan is:	20
11(2)	A responsible person who receives an exemption under sub regulation (1) must ensure that a copy of the exemption is:.....	21
Schedule 1 – Code of Practice For Electric Line Clearance		
Part 2 – Clearance Responsibilities		
Division 1 – Roles Of Responsible Persons		22

(4)	Exception to minimum clearance space for structural branches around insulated low voltage electric lines	22	
(5)	Exception to minimum clearance space for small branches around insulated low voltage electric lines.....	22	
(6)	Exception to minimum clearance space for structural branches around uninsulated low voltage electric lines in low bushfire risk areas.....	22	
(8)	Responsible person may cut or remove hazard tree.....	22	
Schedule 1 – Code of Practice for Electric Line Clearance			
Part 2 – Clearance Responsibilities			
Division 2 – Manner of Cutting and Removing Trees			24
(10)	Cutting or removal of	24	
(11)	Cutting or removing habitat for threatened fauna	24	
Schedule 1 – Code of Practice for Electric Line Clearance			
Part 2 – Clearance Responsibilities			
Division 3 – Notification, Consultation and Dispute Resolution.....			26
(15)	Responsible person must provide notification before cutting or removing certain trees	26	
(16)	Responsible person must publish notification before cutting or removing certain trees	26	
(19)	Dispute resolution	26	
Schedule 1 – Code of Practice for Electric Line Clearance			
Part 2 – Clearance Responsibilities			
Division 4 – Additional Duties of Responsible Persons			26
(20)	Duty relating to the safety of cutting or removal of trees close to an electric line	26	
Schedule 1 – Code of Practice for Electric Line Clearance			
Part 3 – Minimum Clearance Spaces			
Division 2 – Alternative Compliance Mechanisms.....			26
(31)	Application for approval of alternative compliance mechanism.....	26	
(32)	Formal safety assessment of alternative compliance mechanism	27	
Appendix 1 Declared Area and Fire Risk Maps – Avenel		28	
Appendix 2 Declared Area and Fire Risk Maps – Euroa.....		33	
Appendix 3 Notice of Urgent Tree Cutting or Removal		39	
Appendix 4 Sample Inspection Record Form.....		40	
Appendix 5 Sample Screen Shot of Council's Asset Management System (Confirm)		41	
Appendix 6 Sample Publication to Clear Trees.....		42	
Appendix 7 Sample of Council's Asset Management System (Confirm) Works Instruction and Map Base showing the work location		43	
Appendix 8 Strathbogie Shire's Tree Maintenance Management Process.....		45	
Appendix 9 Sample of the General Conditions of Contract AS2124-1992 – Table of Contents		47	

ELECTRIC LINE CLEARANCE MANAGEMENT PLAN PREPARED BY:**Name: Strathbogie Council****Date: March 2018**

The following sections are in response to Regulation 9(2) – Preparation of Management Plan of Part 2 of the Electricity Safety (Electric Line Clearance) Regulations 2015.

9(2)

The Shire of Strathbogie responsible person will review and amend the *Electric Line Clearance Management Plan (ELCMP)* annually prior to the 31 March each year.

The Shire of Strathbogie will submit the *Electric Line Clearance Management Plan* within 14 days of a request.

The following sections are in response to Regulation 9(3) – Preparation of Management Plan of Part 2 of the Electricity Safety (Electric Line Clearance) Regulations 2015.

9(3) (a) Name address and telephone number of the responsible person:

Name: Strathbogie Shire Council ('Council')
Address: 109A Binney Street, Euroa, Victoria 3666
Council Office Telephone No: +61 3 5795 0000
Council Office Facsimile No: +61 3 5795 3550
Email Address: info@strathbogie.vic.gov.au
Chief Executive: Steve Crawcour

9(3) (b) Name, position, address and telephone number of the individual who was responsible for the preparation of the management plan:

Name: Matthew Fraser
Position: Manager Works
Business Address: 109A Binney Street, Euroa, Victoria 3666
Telephone No.: +61 3 5795 0000
Mobile No.: +61 448 876 493
Email Address: matthew.fraser@strathbogie.vic.gov.au

9(3) (c) Name, position, address and telephone number of the persons who are responsible for carrying out the management plan on behalf of the Council:

Name(s): Mr. Roy Hetherington
Position(s): Director Community Assets (DCA)
Business Address: 109A Binney Street, Euroa, Victoria 3666
Telephone No: +61 3 5795 0000
Mobile No.: +61 407 092 050
Email Address: roy.hetherington@strathbogie.vic.gov.au

AND Nominated Representative

Name(s): Mr. Mark Gordon
Position(s): Project Officer
Business Address: 109A Binney Street, Euroa, Victoria 3666
Telephone No: +61 3 5795 0000
Mobile No.: +61 428 597 024
Email Address: mark.gordon@strathbogie.vic.gov.au

9(3) (d) The telephone number of a person who can be contacted in an emergency that requires clearance of an electric line that the responsible person is required to keep clear of trees:

Name: Council's emergency after hours contact number

Emergency telephone no.: **+61 3 5795 0000**

9(3) (e) The objectives of the management plan:

The following objectives are identified to fulfil the obligations as set out in the *Electrical Safety (Electric Line Clearance) Regulations 2015*:

- Public safety.
- To comply with the *Electrical Safety (Electric Line Clearance) Regulations 2015 Code of Practice*.
- Management of trees during vegetation clearance to maximise the amenity value, protect tree health and culturally significant vegetation, habitat for native wildlife and natural environment.
- Community satisfaction with the manner in which the necessary works are performed in relation to the requirements of the Regulations.
- Provision of a safe workplace for Council employees and contractors.
- Continuity of electricity supply to electricity business' customers.
- Minimise the risk of fire by maintaining minimum clearance between vegetation and electric lines in the declared areas for which Council is responsible.
- Ensure electrical safety while conducting electric line vegetation clearing activities.
- Protection of areas of important vegetation where identified.

- Ensure that appropriately qualified staff are undertaking electric line vegetation clearance works.
- Ensure that affected people are informed of the electric line clearance works.

To achieve these objectives, Council has a biannual pruning program for Euroa and Avenel townships which inspects and conducts pruning work on all trees including those near power lines throughout each town.

The clearance works are undertaken by a contractor and are audited by Council's Nominated Representative on completion of each town. Any non-compliance recorded during the audit is required to be rectified by the Contractor within an appropriate timeframe as determined by Council's Nominated Representative in accordance with the works contract.

All objectives are reviewed annually in line with the review and update of the Plan. Refer to Section 9(3) (i) and 9(3) (n) for outline of implementation, monitoring and auditing of objectives and key performance indicators, for which the Executive Manager Assets is responsible.

9(3) (f) The land to which the management plan applies (as indicated on a map):

The Strathbogie Shire covers an area of 3,302 sq.km of which Avenel and Euroa are the only townships within the declared area map with a total area of 7.3sq.km.

Refer to Appendix 1 for a Declared Area and fire hazard rating maps for Avenel.

Refer to Appendix 2 for a Declared Area and fire hazard rating maps for Euroa

The maps referenced are as follows:

Avenel

- Council's Declared Area Map VH6-816. Extent of area 3.030sq.km.
- CFA Fire Hazard Rating Maps current as at May 2013:
 - Avenel A1
 - Locksley A5
 - Nagambie E5

Euroa

- Council's Declared Area Map VH6-801. Extent of area 4.329sq.km.
- CFA Fire Hazard Rating Maps current as at May 2013:
 - Euroa C4
 - Euroa C5
 - Euroa D4
 - Euroa D5

- Note:
1. A large amount of declared area within both Avenel and Euroa carry a CFA "Low Fire Hazard Rating" shown as green on the CFA Fire Hazard Rating Maps Appendix 1 and 2. However, within the declared areas there is Low Bushfire Risk Area (LBRA) and Hazardous Bushfire Risk Area (HBRA).
 2. The declared area boundaries for Avenel and Euroa have been checked against the Plans in the original order in Council.
 3. Current CFA Fire Hazard Rating Maps were supplied by CFA on 15th December 2016, which state that the Maps provided are current as at May 2013 and are reviewed every four years.

9(3) (g) The location of each area that the responsible person knows contains a tree that the responsible person may need to cut or remove to ensure compliance with the code and that is:

(i) Native;

The street trees within the declared areas for the townships of Avenel and Euroa are an eclectic mix of natives and exotics which enhance the amenity of these two towns. There is no one area with each township which is predominantly native in relation to proximity to power lines.

The *Strathbogie Shire Tree Management Plan – Urban and Rural Strategies – Draft April 2016* incorporates actions to protect, conserve and manage its native and exotic vegetation.

The number of trees in Euroa and Avenel impacted by powerlines is 1971. This number of trees is composed of 21% native and 79% exotic.

These trees are located on Council's digital Asset Management System (Confirm) as shown in Appendix 5 Sample Screen Shot.

The Shire has a variety of planning scheme overlays and local laws that specify what may or may not be undertaken with certain type of native vegetation and exotics.

<http://planning-schemes.delwp.vic.gov.au/schemes/vpps/72.pdf>.

Under the Council Planning Scheme native vegetation is defined as:

Native Vegetation: Plants that are indigenous to Victoria, including trees, shrubs, herbs and grasses.

Other planning overlays may include:

- Heritage Overlays with Tree Control.
- Heritage Act 1995 – includes trees of State Cultural Heritage Significance.
- Significant Landscape Overlays.
- Environmental Significant Overlays.
- Public Acquisition Overlays.
- Vegetation Protection Overlays.

Native trees within Council's road reserve are classified under the "Roadside Management Plan" as having the following Conservation Values:

"Low" Poor condition substantially disturbed and/or modified, predominately non-native vegetation, little if any native vegetation on site or adjacent, low natural regenerative capacity and few habitat features. May have some potential for revegetation and habitat improvement; however investment in these areas should only be undertaken if there is a clear biodiversity gain.

"Medium" Moderate disturbance and weed levels (levels could be high at times if annual grassy weeds dominate seasonally), native vegetation occurs mainly in patches, some capacity for natural regeneration few other habitat features, potential to improve conservation values by changes to management and/or vegetation. Probably should be a higher priority for investment or enhancement works than "low" areas.

“High” May include some, but not necessarily all, of the following:
 Relatively lower level of disturbance (may be subjected to disturbance historically but has since regenerated), various vegetation layers present although not necessarily all native vegetation occurs across much of the area, low weed levels (may be seasonally high due to annual weeds), support a range of habitats, may form a wildlife corridor, is linked to other native vegetation, the latter should only be considered if the activities do not adversely impact existing biodiversity values. Opportunities should be explored for vegetation and/or habitat enhancement works to be conducted on adjacent land to increase biodiversity values.

(ii) Listed in a planning scheme to be of ecological, historical or aesthetic significance;

No such tree has been identified in the declared areas for the townships of Avenel and Euroa pursuant to paragraph 9(3) (g) (ii) of the Regulations.

There are planning scheme overlays for Avenel and Euroa which includes Heritage and Vegetation Protection. None of these overlays impact on either Avenel or Euroa Townships in relation to electric line tree clearing.

(iii) A tree of cultural or environment significance;

No such tree has been identified in the declared areas for the townships of Avenel and Euroa pursuant to paragraph (g) (iii) of the Regulations.

However, in Avenel there is a heritage overlay in Mitchell Street in the vicinity of Hughes Creek Reserve that Electric Line Clearance crews will need to be aware of, but will not impact on any electric line clearing.

9(3) (h) The means which the responsible person is required to use to identify a tree of a kind specified in paragraph (g)

The Council will review and update section (g) annually of the regulations.

The Strathbogie Shire Council Planning Scheme overlays do not require a permit for works to keep vegetation clear of an electric line in accordance with the Code of Practice under Part 8 of the *Electricity Safety Act 1998*.

However, should there be a tree of cultural or environmental significance, the Council would refer to:

- The planning overlays outlined in 9(3)(g)(i) includes the web link <http://planningschemes.dpcd.vic.gov.au/schemes/strathbogie>;
- Heritage Register within the meaning of the **Heritage Act 1995** ([http://www.legislation.vic.gov.au/Domino/Web_Notes/LDMS/LTObject_Store/LTObjSt2.nsf/29c45876478ab8bdca2577670022409d/9eba9189708477dfca25776100217b7e/\\$FILE/95-93a042.pdf](http://www.legislation.vic.gov.au/Domino/Web_Notes/LDMS/LTObject_Store/LTObjSt2.nsf/29c45876478ab8bdca2577670022409d/9eba9189708477dfca25776100217b7e/$FILE/95-93a042.pdf)); or
- Victorian Aboriginal Heritage Register established under section 144 of the **Aboriginal Heritage Act 2006** ([http://www.legislation.vic.gov.au/Domino/Web_Notes/LDMS/PubStatbook.nsf/51dea49770555ea6ca256da4001b90cd/481F4F0770858034CA257169001D1F4A/\\$FILE/06-016a.pdf](http://www.legislation.vic.gov.au/Domino/Web_Notes/LDMS/PubStatbook.nsf/51dea49770555ea6ca256da4001b90cd/481F4F0770858034CA257169001D1F4A/$FILE/06-016a.pdf)); or
- Flora or a habitat of fauna listed as threatened in accordance with section 10 of the **Flora and Fauna Guarantee Act 1988** (<http://www.delwp.vic.gov.au/environment-and-wildlife/conserving-threatened-species-and-communities/flora-and-fauna-guarantee-act-1988>); or

- (i) Flora listed in the Threatened Flora list with a conservation status in Victoria of “endangered” or “vulnerable”, or
- (ii) A habitat of fauna which is:
 - listed in Threatened Invertebrate fauna list with a conservation status in Victoria of “vulnerable”, “endangered” or “critically endangered”, or
 - Listed in the Threatened Vertebrate Fauna List with a conservation status in Victoria of “vulnerable”, “endangered” or “critically endangered”.

After which the qualified arborist undertaking site inspection would note the location on Council’s digital Asset Management System (Confirm). Council’s Nominated Representative is responsible for checking such information on the Asset Management System (Confirm). The review will occur as part of the biannual line clearing inspections by a qualified arborist.

The process for tree identification is provided in the *Shire of Strathbogie – Tree Management Plan - Draft April 2016*. Once the final report is adopted, a copy of the Tree Management Plan will be placed on Council’s website.

9(3) (i) The management procedures that the responsible person is required to adopt to ensure compliance with the Code, which must:

- (i) Include details of the methods to be adopted for managing trees and maintaining a minimum clearance space as required by the code;**

The Shire of Strathbogie will manage its trees as per the following:

- The “*Shire of Strathbogie – Tree Management Plan – Urban & Rural Strategies – Draft April 2016*” is a comprehensive document providing guidance, strategies and directives on a range of tree management activities. Once adopted, the Tree Management Plan will be made available for inspection at the Council offices in Binney Street Euroa. The draft Tree Management Plan incorporates strategies in relation to electric lines including the following:
 - Aerial Bundled Conductor (ABC).
 - The undergrounding of existing and proposed overhead powerlines.
 - Redirecting of power line routes.
 - Pruning to provide long term clearance.
 - Removal of unsuitable species.
 - The use of appropriate plant selection for new and replacement plantings taking into consideration the mature height of the tree, degree of fire resistance, performance with regard to litter, fruit drop, strength of branch attachment and toxicity to animals.
 - Refer to Appendix 4 for a sample Digital Asset Management System (Confirm) for inspections and refer to Appendix 5 for an example of all trees by type shown by colour included in the Asset Management System (Confirm).
 - Refer to Appendix 7 for a sample digital Asset Management System (Confirm) instruction and map location of the work for tree clearance management.
- Council takes into consideration a number of factors in the decision making process to decide on the appropriate technique or course of action taken in each particular case.
- Council has approximately 562 trees in Avenel and 1409 trees in Euroa, a total of 1971 trees affected by the Electric Line Clearance Management Plan.

- The Shire of Strathbogie engages external service providers to assist with the inspection and pruning of trees within the affected streets in the declared areas for the townships of Avenel and Euroa. A sample copy of the relevant contracts along with a detailed tree list for pruning can be made available for inspection at the Council's offices in Binney Street Euroa if required.
- The Council will ensure that the affected trees within the declared areas are inspected on a biannually in accordance with the Inspection Program in Table 1 for potential problems associated with tree growth in the clearance zone around the electric lines. The inspections will be undertaken by suitably qualified and experienced personnel and will identify:
 - Trees that are in breach of the Code.
 - Any trees which are likely to breach the Code will be pruned the following month in accordance with the Pruning Program in Table 1.
 - Any hazards outside the clearance and regrowth spaces that may require some corrective or pre-emptive action.
 - Inspections are digitally recorded on a form that is then used to allocate a clearance works priority rating (P1 through P6), which is recorded in Council's Asset Management System (Confirm). Refer to Appendix 4 for a sample inspection form and Appendix 8 for the Tree Management Process.

P1 rating requires immediate/now action

P2 rating requires priority programming within current cycle

P3 rating requires programming within current cycle

P4 rating requires no action

P5 rating proactive works

Pruning works are scheduled based on the P rating and within a timeframe that avoids an escalation of the rating.

Table 1 – Inspection and Pruning Program Timelines

Zone	No. of Trees	1 st Inspection	2 nd Inspection	KPI	Who
Inspection Program					
Avenel Township Declared Area	562	September	March	Inspection data received, reviewed and updated prior to forwarding to line clearance contractor.	Qualified Appointed Arborist.
Euroa Township Declared Area	1409	September	March	Inspection data received, reviewed and updated prior to forwarding to line clearance contractor.	Qualified Appointed Arborist.
Pruning Program					
Zone	No. of Trees	1 st Prune	2 nd Prune	KPI	Who
Avenel Township Declared Area	Determined by Work Program-Asset Management System (Confirm)	October	April	Complete all works as instructed as per the works instructions. Refer Appendix 7 sample.	Qualified Nominated Contractor.
Euroa Township Declared Area	Determined by Work Program-Asset Management System (Confirm)	October	April	Complete all works as instructed as per the works instructions. Refer Appendix 7 sample.	Qualified Nominated Contractor.
Audit of Works					
Zone	No. of Trees	1 st Prune	2 nd Prune	KPI	Who

Zone	No. of Trees	1 st Inspection	2 nd Inspection	KPI	Who
Avenel Township Declared Area	Check the work is completed as per Asset Management System (Confirm) works program. Issue any non-compliance and follow up	October	April	Sample Audit undertaken by 30 th October and 30 th April each year	Council Nominated Representative.
Euroa Township Declared Area	Check the work is completed as per Asset Management System (Confirm) works program. Issue any non-compliance and follow up	October	April	Sample Audit undertaken by 30 th October and 30 th April each year	Council Nominated Representative.

- The Council will work with its contractors to ensure that the tree audits and appropriate pruning measures are undertaken to maintain compliance with the Code and to the Australian Standard AS4373-2007 'Pruning of amenity trees'.
- The amount of pruning required to allow adequate allowance for regrowth before the next inspection will be calculated using: "*Average annual growth extension since last prune x years to next inspection/prune = amount to be pruned.*"
- Historically Council has worked with Australian Tree Management (ATM), Eastern Energy, TXU, T-squared, Tenix Alliance, and Eastern Tree Service to perform the tree audits and undertaking the subsequent pruning requirements as identified. It is anticipated that working arrangements will continue with these organisations for the life of this Plan.
 - A pre-commencement meeting is held with the successful contractor in accordance with the Contract and the meeting is minuted by Council Project Officer. Council's Project Officer also inspects and approves the Contractors Site Management Plan including SWMS, Inductions and Tool Box Meetings during the course of the contract period. The Contractors performance is assessed at Practical Completion of the Contract and any Omissions or

Defects noted for rectification by the Contractor are attended to within a four week period.

- Council relies on the pruning contractor's integrated business management system to facilitate the satisfactory compliance with the Code and the Australian Standard. Notwithstanding this, Council will continue to monitor and explore opportunities both inside and outside of this relationship to fulfil its responsibilities to best practice standards.
- If the Distribution Company identifies locations that require attention to maintain the electric line clearance requirements, and these locations are the responsibility of the Council, they shall notify the Council. The Council's Director Community Assets (DCA) or Nominated Representative shall assess the scope of the works identified in the notice, and program the works as required.

Note: Any reference to the Distribution Company in this plan refers to AusNet Services

- If any street tree re-grows into the clearance zone before the bi-annual pruning program takes place, the DCA, or their representative, shall contact Council's clearance contractor and arrange for the offending regrowth to be removed.
- The Shire of Strathbogie and its Service Providers are responsible for organising any 'Shutdowns' or 'Suppressions' that become necessary to undertake pruning works.
- The Shire's DCA, or Nominated Representative is responsible for liaising with the relevant Distribution Company should the distribution company wish to discuss any aspects of the electric line clearance works e.g. 'Shutdowns' or 'Suppressions', potential non-compliances' etc. Meetings will be arranged with the Distribution Company once per year and include an Agenda and Minutes of meeting by the Shire's Nominated Representative. Items on the agenda include:
 - ELCMP Program for the year including dates.
 - Any update to any Hazardous Bushfire Risk Areas (HBRA) within Council's declared area.
 - Spans greater than 45m and any changes to the total number of spans.
 - Hazard tree assessment and timing.
 - Performance including notification of works, non-conformance and any other issues.
 - Performance of Contractors.
 - Provision of updated contact details.
- The techniques discussed above are relevant for minimising the adverse effects of electric lines on Council's street trees within the declared areas for Avenel and Euroa. However, Council will also use these techniques, together with other practices, to minimise the adverse effects of electric lines on street trees in the various other towns within the Shire.

(ii) Specify the method for determining an additional distance that allows for cable sag and sway;

The declared areas for the townships of Avenel and Euroa primarily incorporate residential zoned land. Accordingly, it is anticipated that the majority of the spans would not exceed 45m in length. However, should longer spans be identified, the Council would liaise with the relevant Distribution Company to determine the additional clearance allowances for sag and

sway. The Shire's Director Community Assets or Nominated Representative is responsible implementing this process.

The AusNet Services Contact is Nick Iwanov, ORP Liaison Officer, email:

nick.iwanov@ausnetservices.com.au

Clearance requirements for spans >45m and up to 100m is provided in Schedule 2 of the 2015 Electric Line Clearance Regulations Graphs 2-4, Graphs 5-6 require additional sag and sway >45m.

The calculations of sag and sway are to be included into Council Tree Maintenance System (refer Appendix 4) under the item titled 'Conditions'. The Council DCA or Nominated Representative is to check for any sag and sway >45m and ensure that the Tree Pruning Inspection Contractor has recorded the details into Council's Tree maintenance system so that the tree pruning Contractor is aware of the pruning requirements for the particular tree in question.

Contractors are responsible for pruning to achieve the clearance space outlined in the Code and Australian Standard AS4373-2007. Council's Nominated Representative is required to inspect the Contractors Site Management Plan to ensure the most current version of AS4373 is being applied.

The Shire will provide the works program and additional information for pruning to achieve the required clearance space to the nominated Contractor to perform the tree clearance works. The Shire records these sag and sway calculations in the Asset Management System (Confirm) where they will be maintained for at least five years.

9(3) (j) The procedures to be adopted if it is not practicable to comply with the requirements of AS4373 while cutting a tree in accordance with the code;

Council's contractors who conduct the arboriculture inspections have Level 4 qualifications in Horticulture and Arboriculture and above or at least three years of field experience in assessing trees.

The Shire of Strathbogie and its service providers shall attempt to cut trees in accordance with AS4373-2007 or most current version unless it is deemed not practicable to do so, that is it would not be safe to do so or the desired outcome would not be achieved. In such instances, the matter shall be referred to the Director Community Assets, or Nominated Representative, for assessment prior to any pruning works on that tree.

Council's Nominated Representative is required to ensure that Council has the most current version of AS4373 prior to nominating a Contractor to undertake any tree clearance works. The Nominated Representative is also required to check that the Contractor has the most current version of AS4373, included in the Site Management Plan before commencement of works.

Any tree pruning inspection that considers pruning of a particular tree as not practicable in accordance with the standard shall include details and method into Council's Tree Maintenance System –'Conditions' Refer to Appendix 4. This will then alert the Pruning Contractor to the particular tree and method.

The Pruning Contractor shall determine the plant and equipment necessary for the method.

The Tree Pruning Contractor will give consideration to alternatives such as an engineering solution prior to any cutting not in accordance with AS4373-2007. The Tree Pruning Contractor may also liaise with the Distribution Company for a solution.

The Director Community Assets, or Nominated Representative, must approve all cutting not in accordance with AS4373-2007.

The Shire of Strathbogie is responsible for notifying affected residents when required regarding cutting that is not undertaken in accordance with AS4373-2007.

9(3) (k) A description of each alternative compliance mechanism in respect of which the responsible person has applied, or proposes to apply, for approval under clause 31 of the code;

The Council is not intending to apply for any alternative compliance mechanism under clause 31.

9(3) (l) The details of each approval for an alternative compliance mechanism that:

(i) The responsible person holds;

(ii) Not applicable in effect;

Not applicable

9(3) (m) A description of the measures that must be used to assess the performance of the responsible person under the management plan;

The Contract requires completion of works within the specified timeframe and there are weekly updates between the Contractor and Nominated Representative.

The Electric Line Clearance Management Plan is intended to proactively identify and attend to trees to maintain clearance requirements in accordance with the Code. Accordingly, requests for pruning from external parties should be minimal and as such a measure of performance would be:

- Number of pruning requests from the Distribution Companies.
- Number of pruning requests from the community.

The records are kept in Council's customer requests tracking system 'Confirm' or records management system 'InfoWise'.

Other performance measures in relation to the Inspection and Pruning Works are audited by Council's Director Community Assets or Nominated Representative in accordance with the contract. Council's Director Community Assets is responsible for ensuring that the biannual inspections and pruning timelines in Table 1 are compliant.

9(3) (n) Details of the audit process that must be used to determine the responsible person's compliance with the Code;

The Electric Line Clearance Management Plan requirements will be reviewed in March each year to confirm compliance with the requirements and to check the status of the Plan's actual implementation against the programmed implementation.

The outcomes of the review will be reported to the Director Community Assets for consideration and appropriate action if required.

- (i) Council's Responsible Persons Performance.

The DCA and Nominated Representative are responsible for monitoring the performance measures and successful completion of actions outlined in this ELCMP, and is audited by the Executive Manager Assets.

Council will be considered to be performing in accordance with the ELCMP if:

- Works are planned utilising bi-annual inspection data, previous years' data on workload (locations, hours) provided by contractors as well as pruning requests and non-conformances from residents and the Distribution Company. Supply outage information is supplied to Council by the Distribution Company. The purpose of planning is to ensure the Council budgets appropriately to undertake works.
- Electric line clearances are in accordance with the Code.
- Requests for clearance/non-compliance from the Distribution Company are minimised and, by agreement, incorporated into the bi-annual clearance works or if urgent completed within the agreed timeframe. These are recorded and monitored in Council's document management system.
- Complaints are no more than five per year. These are recorded in Council's correspondence management system.
- Details of works completed in each electric line clearance area are recorded.
- No deviations have occurred from the cycles outlined in the plan.
- No fires have been identified as having started as a result of foliage touching wires.
- No vegetation damage has resulted from inadequate or substandard pruning practices. Random inspections of works will be undertaken to ensure they are adequate and up to standard.
- No trees have been removed without expert advice being received.
- Preparation of an Electrical Line Clearance Management Plan (ELCMP) prior to 31 March of each year.
- Processes are reviewed in line with the review and preparation of the next year's Plan.

In inadequate processes are observed, the matter is reported and referred to the Manager Works.

All processes and each stage of work are recorded and monitored in line with the Asset Management System (Confirm), including

- Bi-annual street tree assessment and pruning requirements are recorded. The assessment shall be dated, outline the extent of works required and identify specific trees which require other further assessment.
- Actions and decisions resulting from further assessment are to be recorded.
- Work programs including dates, times and extent of work are to be recorded.
- Correspondence sent and received from the Energy Safe Victoria shall be placed on file.
- Correspondence related to clearance and vegetation management shall be placed on file.
- All complaints or requests from the Distribution Company, residents, staff, CFA etc., are recorded, acted upon and responded to accordingly.

(ii) Contractor's Performance

The Tree Inspection Arborist and Tree Pruning Contractors are audited under the contract to ensure compliance with the contract.

Compliance items include, and are not limited to:

- Current ELCMP compliance.
- Vegetation clearance is code compliant.
- Emergency clearances compliance.
- Clearing not meeting quality requirements (AS4373).
- Work Site Management/HSE.
- Personnel qualifications and competency.
- Customer satisfaction.
- Satisfactory completion of works including entering data into Council's Tree Management System.

The performance of the contractors is measured against Council's contract requirements including the General Conditions of Contract.

At completion of pruning works an inspection is undertaken by the DAS or Nominated Representative and any omissions and defects noted for rectification before final certification can be issued in accordance with the General Conditions of Contract.

Failure by the Contractor to remedy any omissions and defects within the required timeframe can result in the DCA arranging for works to be done at the Contractors cost by another accredited ELC Contractor.

Pruning contractors who fail to perform work in accordance with the Contract will not be considered by the DCA in future assessment for pruning contracts unless the accredited Contractor can demonstrate improvement in procedures and systems.

The records of all contracts are kept in Council's records management system "InfoWise".

9(3) (o) The qualifications and experience that the responsible person must require of the persons who are to carry out the inspection, cutting or removal of trees in accordance with the Code;

The Council requires that all the work conducted on trees is conducted by appropriately trained and experienced workers. The workers are required to hold formal qualifications in either arboriculture or horticulture, or have suitable experience as specified elsewhere in the ELCMP.

The DCA or Nominated Representative can instruct the Contractor to stop work and immediately remove any personnel from the work site if qualifications and experience is not to the standard required.

The Council relies upon the experience, expertise, quality management, OH&S systems and environmental management systems of its contractors. These systems are reviewed by the DCA to ensure that they comply with Council's requirements and ELCMP.

The Council will ensure that the Contractors engaged for any cutting, removal or pruning work comply with Australian Standards AS4373-2007.

For the individual tasks to be carried out under the ELCMP, the following certificates and experience would be considered the minimum standard for the relevant staff on site:

- A minimum 3 years of experience.
- Have a UET20312C Certificate II in ESI Powerline Vegetation Control.
- First Aid -Level 1
- Safety Observer for Operations in Electrical Environment
- Chipper Operations Certificate
- Chainsaw Operations Certificate
- OH&S

The Contractor shall not engage an unauthorised person to undertake the tree pruning in the vicinity of powerlines. The Council will ensure that the persons undertaking the work observe and apply the requirements listed in Electricity Safety (Installations) Regulations 2009- r.318 & r.319 including;

- Letting the owner of the infrastructure know prior to any pruning
- All the personal undertaking work to comply with the “Blue Book”.
- All the personal undertaking work to complete a course approved by Energy Safe Victoria.

The Contractor shall submit a Works Management Plan to the Council’s DCA or nominated representative for approval prior to commencement. Such information shall include, but not be limited to:

- Contact details.
- Induction.
- Certificates.
- Insurances.
- HSE.
- SWMS.
- JSA’s.
- Traffic Management Plans.
- Tool Box Meeting Standard Format.
- Declared Area Maps.
- Council’s Tree Management System Data.

Should the Contractor fail to comply with any aspect of the Contract the DCA shall instruct the Contractor within accordance with the General Conditions of Contract.

Training and Authorisation:

The following training, authorisation requirements and actions will be applied to demonstrate acceptable levels of competence with regard to skills, knowledge and experience, both upon appointment and on-going:

- Both initial and refresher training certificates are provided to Council prior to commencement.
- Skills and competence shall be maintained through regular refresher training.
- All training shall be provided by a Registered Training Organisation.
- A record of the sighting of the required certificates and associated documents may be kept by the DCA or nominated representative. All certificates shall be reviewed by the DCA prior to commencement of electric line clearance works.

9(3) (p) Notification and consultation procedures, including the form of the notice to be given in accordance with Division 3 of Part 2 of the Code;

The Council is the responsible person as defined under Section 84C of the Act. Accordingly, Council is not required to give notice under Division 3 clause 15(2) (a).

Notwithstanding the above, Council’s Nominated Representative notifies affected residents of electric line clearing of urgent works. Refer to Appendix 3 for an example of the ‘Notice of Urgent Tree Cutting or Removal.’

However, all programmed works (other than of an urgent works nature) the Council’s Nominated Representative is to publish the line tree clearing programme in a newspaper or newsletter circulating generally in the locality of the land in which the trees is to be cut or

removed. For an example of the 'Public Notice-Notification of Tree Pruning' refer to Appendix 6.

Programmed works is required to be published 14 days and not more than 60 days to pruning works beginning.

The Contractor cannot commence programmed works until the notification or publication has occurred or unless instructed by the DCA or Nominated Representative to undertake urgent work. Refer to Schedule 1 – Division 2 – Manner of Cutting and Removing Trees.

9(3) (q) Dispute resolution procedures;**a. Internal Dispute Resolution;**

The Council will resolve disputes with the Contractor on issues relating to the pruning of Council controlled trees in the declared areas in accordance the General Conditions of Contract. The nominated arbiter under the General Conditions of Contract shall be:

Contact Officer:	Steve Crawcour
Position:	Chief Executive Officer
Address:	109A Binney Street, Euroa, Victoria 3666
Telephone:	+61 3 5795 0000

A sample copy of the General Conditions of Contract AS2124-1992-Table of Contents is attached in Appendix 9. Council may elect to use other General Conditions of Contract and the Executive Manager Assets is required to update the ELCMP if this occurs.

The dispute resolution process for Pruning Contractors is set out in the General Conditions of Contract AS2124-1992 – Clause 47.

b. External Dispute Resolution

For all external disputes between Council, property owners and other stakeholders (e.g. Distribution Businesses) the Council's Dispute Resolution Policy shall be followed and if unsuccessful in resolving the issue, the plaintiff will be referred to the Victorian Ombudsman.

A copy of Council's Policy – Customer Service Charter can be inspected at the Council Office in Euroa or on Council website:

www.strathbogie.vic.gov.au/images/Plans_policies_Strategies_reports/Service%20Charter.pdf

A copy of the Dispute Resolution Policy is available for inspection at the Council's Euroa Office during normal business hours. The process and responsible persons is outlined in the Policy.

9(4) A method for determining and additional distance that allows for cable sag and sway may provide for different additional distances to be determined for different parts of a span of an electric line;

Covered under clause 9(3) (i) (ii).

10(7) The responsible must ensure that a copy of the management plan is:**(a) Published on the responsible person's internet site.**

The current version of the ELCMP is available for inspection on the Shire of Strathbogie's website: <http://www.strathbogie.vic.gov.au/>

Any revised version of the ELCMP is to be published on the Council internet site by 31 March each year.

The superseded ELCMP is to be removed from the internet site at this time.

- (b) Available for inspection at the responsible person's principle office in the State during normal business hours.**

A current version of Council's "Electric Line Clearance Management Plan 2017/2018" is available at Council's Euroa Office at 109A Binney Street, Euroa, VIC 3666 for inspection during normal office hours. The current version is to be available at the Council Office by the 31 March each year.

The superseded ELCMP is to be removed from the office at this time.

-
- 11(2) A responsible person who receives an exemption under sub regulation (1) must ensure that a copy of the exemption is:**

- (a) Published on the responsible person's internet site; and**
(b) Available for inspection at the responsible person's principle office in the State during normal business hours.

The Council currently holds no exemptions.

SCHEDULE 1 – CODE OF PRACTICE FOR ELECTRIC LINE CLEARANCE
PART 2 – CLEARANCE RESPONSIBILITIES
DIVISION 1 – ROLES OF RESPONSIBLE PERSONS

(4) Exception to minimum clearance space for structural branches around insulated low voltage electric lines

Council does not intend to apply an exception

(5) Exception to minimum clearance space for small branches around insulated low voltage electric lines

Council does not intend to apply an exception.

(6) Exception to minimum clearance space for structural branches around uninsulated low voltage electric lines in low bushfire risk areas

Council does not intend to apply an exception.

(8) Responsible person may cut or remove hazard tree

Trees are inspected biannually by the Council's contracted service provider and include the following process.

- (i) Council will ensure that all trees are assessed by a suitably qualified Arborist that holds a minimum Arboriculture Certificate Level IV and has at least three years field experience in assessing trees.
- (ii) The assessment will consider all locally foreseeable conditions that it is reasonable to assess within the scope of the expertise of the inspecting Arborist that indicate the likelihood of contact with an electric line or overhead conductors, i.e. under, over or beside.
- (iii) A visual tree assessment will be recorded on a form that is then used to allocate a clearance works priority rating (P1 through P5). This is recorded in Council's Tree Management Database. Refer to Appendix 4 for a sample digital inspection form and Appendix 8 for the Tree Management Process.

P1 rating requires immediate/now action

P2 rating requires priority programming within current cycle

P3 rating requires programming within current cycle

P4 rating requires no action

P5 rating proactive works

Pruning works are scheduled based on the P rating and within a timeframe that avoids an escalation of the rating.

Items (i) to (iii) inclusive is managed, reviewed and audited by Council's DCA or Nominated Representative.

- (iv) If a member of the public, Council staff, CFA or Distribution Company identifies and reports a hazard tree outside of the scheduled bi-annual program, a qualified arborist will conduct an assessment of the tree, and if that assessment confirms the likelihood of contact with an electric line having regard to foreseeable local conditions, the tree may be cut or removed by the responsible person. Council's Nominated Representative will record the report in Council's Tree Management Database, including details such as: location of tree; name and contact details of reporter; why the tree is a hazard, and if it's deemed urgent.

If deemed urgent Council's Nominated Representative is responsible for arranging for the tree to be pruned by an accredited contractor.

If Council is not responsible, details of the report are forwarded to AusNet Services or other responsible parties as soon as practicable. If it is Council's responsibility, works on a hazard tree will be actioned depending on the urgency or risk priority identified during the assessment.

- (v) The Council's Nominated Representative is required to notify the affected persons:
- For urgent works by placing a Notice in the letterbox of the abutting properties impacted by the Work, refer Appendix 3.
 - For General programmed works in writing or by publication in a newspaper circulating generally in the locality of the land in which the trees is to be cut or removed at least 14 days and not more than 60 days before the intending cutting or removal is to occur.
- (vi) The Contractor must not cut a tree further than 1m from the minimum clearance space for a span of an electric line whilst undertaking emergency or urgent cutting.
- (vii) The Contractor will remove or prune branches of trees considered urgent from within the vicinity of the power lines. When the Contractor is instructed to undertake urgent work, the Council DCA or Nominated Representative will be required to notify,
- All affected persons.
 - The occupier of land on which the tree was cut or removed.
 - If a tree was removed-the owner of land on which the tree was removed;

After completion of the work copies of the notifications are to be placed on Council's records management system.

SCHEDULE 1 – CODE OF PRACTICE FOR ELECTRIC LINE CLEARANCE
PART 2 – CLEARANCE RESPONSIBILITIES
DIVISION 2 – MANNER OF CUTTING AND REMOVING TREES

(10) Cutting or removal of:

- **Native trees**
- **Trees listed in the planning scheme to be of ecological, historical or aesthetic significance**
- **Trees of cultural or environmental significance**

Must be minimised

Native Trees

There are native trees affected by the Electric Line Clearing Management Plan. To keep the impact on native trees to a minimum whilst at the same time complying with the clearance requirements of the Code, the Council will:

- Provide a copy of Council's Asset Management System (Confirm) which identifies the various types of tree, for an example refer to Appendix 5.
- Use only suitably qualified and experienced people to undertake the inspection assessments.
- Use only suitable qualified and experienced contractors to undertake electric line pruning of trees.
- Restrict the cutting or removal of the trees in accordance with Australian Standards AS4373-2007.
- Frequently prune the trees rather than making a big cut by undertaking biannual inspections.

Trees listed in the planning scheme to be of ecological, historical or aesthetic significance

There are no such trees listed in the planning scheme within the declared areas for the townships of Avenel and Euroa.

Trees of cultural or environmental significance

There are no identified areas or trees of special or particular significance. Should a tree of cultural or environmental significance become identified, the Council would:

- Check its obligations under the relevant Acts and instruct the inspector and clearing contractor accordingly.
- Restrict the cutting or removal of the trees in accordance with Australian Standards AS4373-2007.
- Frequently prune the trees rather than making a big cut.

(11) Cutting or removing habitat for threatened fauna

With regard to threatened fauna the Council would:

- As part of the on-going inspection program aim to identify if fauna using the tree is a threatened species.
- If fauna is spotted during the inspections and is not readily identifiable an appropriately qualified zoologist would be engaged to assist with recognition and breeding season

- Any threatened fauna spotted during the inspection is to be noted on the Council Asset Management System (Confirm) so that Clearing Contractors will have the required information.
- The cutting or removal of a confirmed habitat tree for threatened fauna would only be undertaken outside of the breeding season for the identified fauna or after the fauna has been relocated as directed by the DCA nominated representative.

SCHEDULE 1 – CODE OF PRACTICE FOR ELECTRIC LINE CLEARANCE
PART 2 – CLEARANCE RESPONSIBILITIES
DIVISION 3 – NOTIFICATION, CONSULTATION AND DISPUTE RESOLUTION

(15) Responsible person must provide notification before cutting or removing certain trees

Refer to clause 9(3) (p).

(16) Responsible person must publish notification before cutting or removing certain trees

Refer to clause 9(3) (p).

(19) Dispute resolution

Refer to clause 9(3) (q).

SCHEDULE 1 – CODE OF PRACTICE FOR ELECTRIC LINE CLEARANCE
PART 2 – CLEARANCE RESPONSIBILITIES
DIVISION 4 – ADDITIONAL DUTIES OF RESPONSIBLE PERSONS

(20) Duty relating to the safety of cutting or removal of trees close to an electric line

The declared areas within the Strathbogie Shire are with the one Distribution Company – Aus Net Services.

If the Council has particular concerns about the safety of cutting or removing of a tree close to an electric line then the Council's DCA or Nominated Representative will consult with the relevant Distribution Company - AusNet Services prior to any works being undertaken.

The contact person at AusNet Services details is provided in Section 9(3) (ii).

The DCA or Nominated Representative shall make a note of the discussion and agreed outcome be placed on Council's record management system "InfoWise" for the required action if any.

SCHEDULE 1 – CODE OF PRACTICE FOR ELECTRIC LINE CLEARANCE
PART 3 – MINIMUM CLEARANCE SPACES
DIVISION 2 – ALTERNATIVE COMPLIANCE MECHANISMS

(31) Application for approval of alternative compliance mechanism

The Shire of Strathbogie may apply to Energy Safe Victoria for approval to use an alternative compliance mechanism in respect of a span of an electric line or a class of spans. An application would include details of:

- The alternative compliance mechanism.
- The procedures to be adopted for the commissioning, installing, operating, maintaining and decommissioning the alternative compliance mechanism.

- The published technical standards that would be complied with when commissioning, installing, operating, maintaining and decommissioning the alternative compliance mechanism.
- Describe the location of the affected span or describe class of spans.
- Specify the minimum space that the applicant proposes is to be applied in relation to the span, or class of spans, in respect of which the application is made.
- Include a copy of a formal safety assessment relevant to the alternative compliance mechanism as prepared by the distribution company under clause 32.
- Include written agreement for the use of an alternative compliance mechanism from the owner or operator of the span and is not owned by the applicant.
- Include written agreement in respect of a class of spans that the span belongs to that class and is not owned by the applicant.

(32) Formal safety assessment of alternative compliance mechanism

The Shire of Strathbogie does not have the qualified personnel to undertake a formal safety assessment. This would be undertaken by the distribution company or an alternative qualified provider would be enlisted.

Appendix 1 Declared Area and Fire Risk Maps – Avenel

Avenel Declared Area Map from Council’s Asset Management System (Confirm)

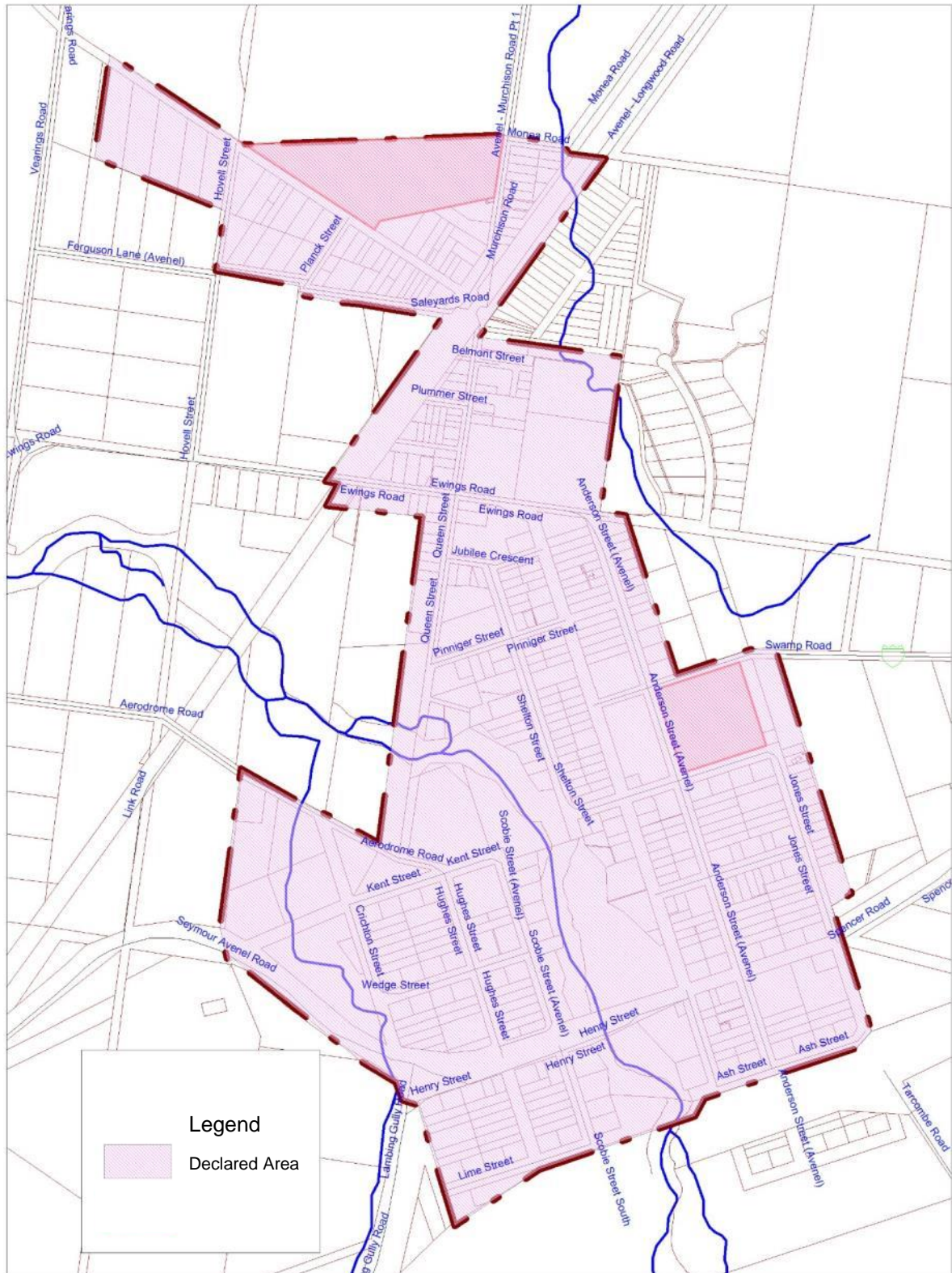

**FIRE HAZARD RATINGS
(THE ELECTRICITY SAFETY ACT 1998, REVISED 2010)**



**Spatial Information
Services**

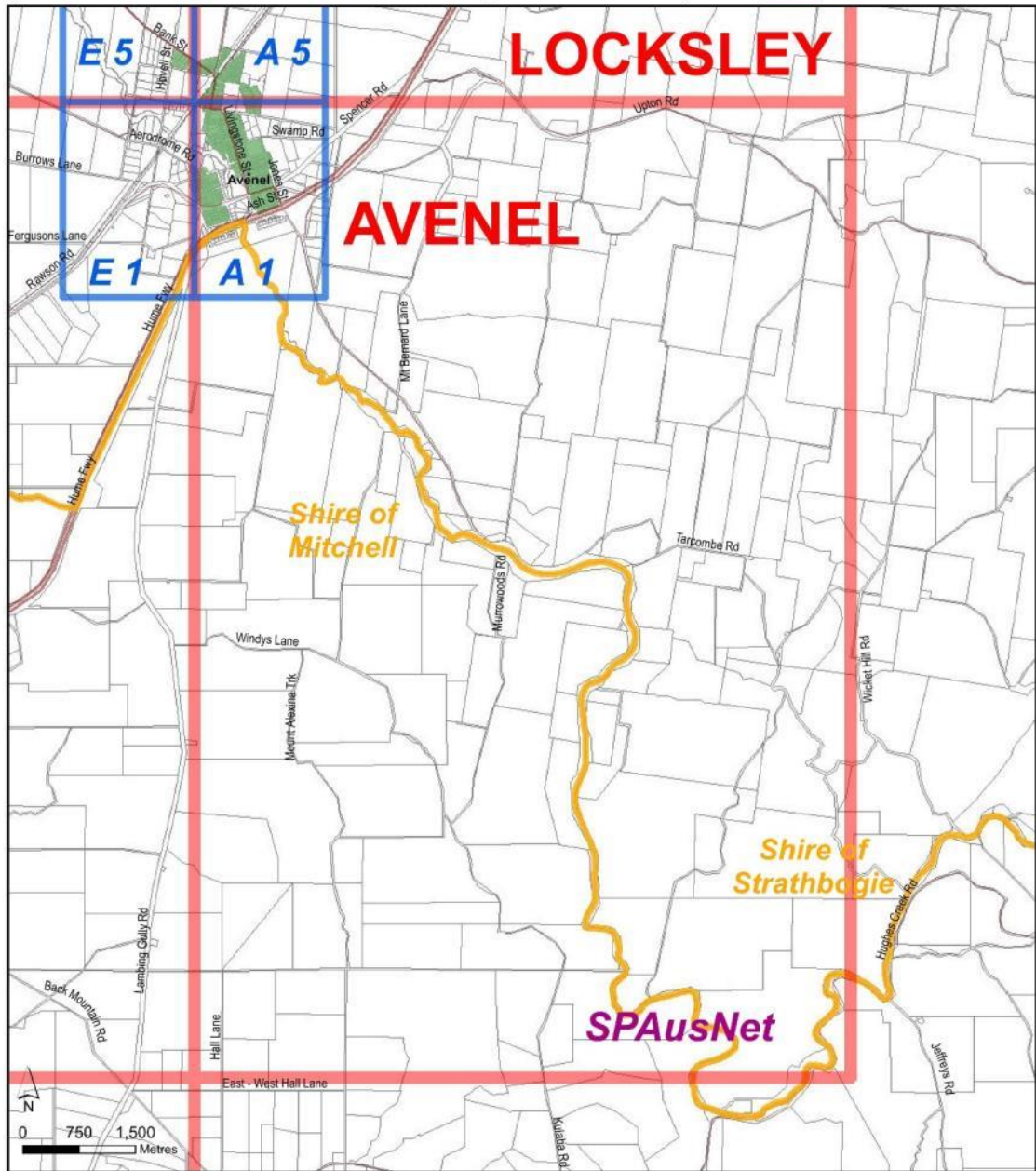

AVENEL 1:50 000

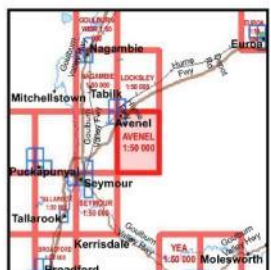

Fire Hazard Ratings assigned for Part 8 & 80 of the Electricity Safety Act 1998 (revised 2010) to the Country Area of Victoria (CAV) within the meaning of the Country Fire Authority Act 1958 and the Metropolitan District (MD) within the meaning of the Metropolitan Fire Brigades Act 1958.

PLEASE NOTE:

- The Department of Sustainability and Environment (DSE) has no collaboration with CFA during municipality reviews of Fire Hazard Ratings for Powerlines where the municipality contains both CAV and Public Land under the control of the Secretary of the DSE. Under the Forests Act 1958 they have NOT been assigned fire hazard ratings. The DSE assigns all Public Land to 'high' fire hazard rating.
- The MFB has collaborated with the CFA to review municipalities that share CAV and MD. Except for the parts that are public land under the control of the Secretary of the DSE & the parts specified in the maps published by CFA having an assigned 'high' fire hazard rating, the remaining MD is assigned 'low' fire hazard rating.

The CFA, on a four year cycle, reviews the Fire Hazard Ratings for Powerlines in all municipalities where the CAV has been assigned. The maps displays data for areas assigned 'low' fire hazard ratings only.

Vicmap Digital Property and Vicmap Digital Transport data sets on licence from Spatial Information Infrastructure, DSE. Overhead powerline and power pole data on licence from SP AusNet, PowerCo, UED and Jemena. No High Voltage and Low Voltage underground powerline as well as overhead transmission line data (in excess of 66kV) are displayed.

USERS ACCEPT THAT THEY HAVE READ AND FULLY UNDERSTOOD ALL ASSOCIATED COPYRIGHT AND DISCLAIMER STATEMENTS.

FIRE HAZARD RATINGS ARE CURRENT AS AT MAY 2013.

Legend

- Low Fire Hazard Ratings
- Undefined Fire Hazard Ratings
- Parcel / Property
- Power Distribution Co. Boundary
- Local Government Areas (LGAs)
- Lakes
- Major Watercourses
- Freeway / Highway
- Main Roads

**FIRE HAZARD RATINGS
(THE ELECTRICITY SAFETY ACT 1998, REVISED 2010)**



**Spatial Information
Services**

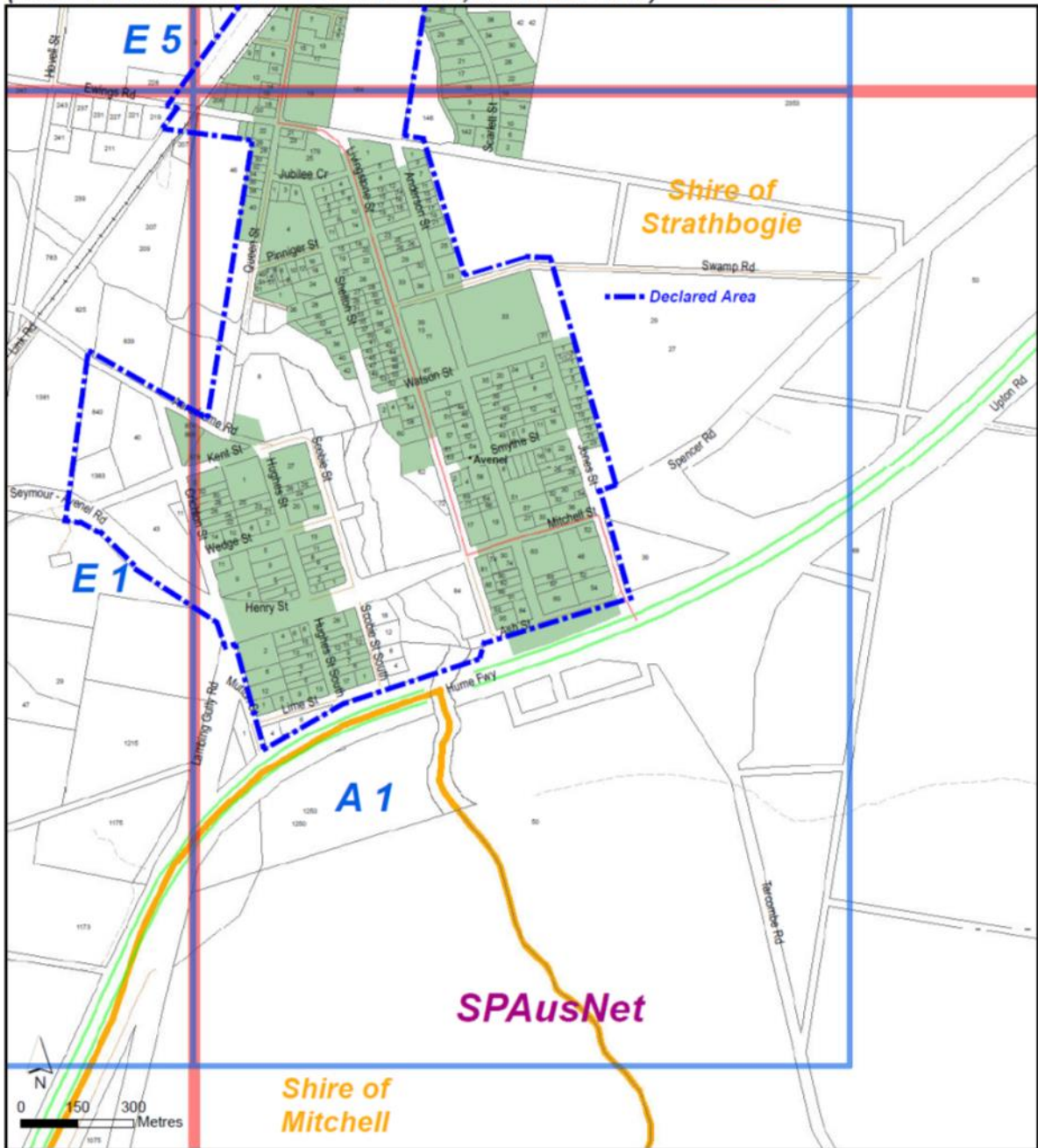

AVENEL A 1 MAP 1:10 000



Fire Hazard Ratings assigned for Part 6 § 80 of the Electricity Safety Act 1998 (revised 2010) to the Country Area of Victoria (CAV) within the meaning of the Country Fire Authority Act 1958 and the Metropolitan District (MD) within the meaning of the Metropolitan Fire Brigades Act 1958.

PLEASE NOTE:
 - The Department of Sustainability and Environment (DSE) has no collaboration with CFA during municipality reviews of Fire Hazard Ratings for Powerlines where the municipality contains both CAV and Public Land under the control of the Secretary of the DSE. Under the Forests Act 1958 they have NOT been assigned fire hazard ratings. The DSE assigns all Public Land to 'high' fire hazard rating.
 - The MFB has collaborated with the CFA to review municipalities that share CAV and MD. Except for the parts that are public land under the control of the Secretary of the DSE & the parts specified in the maps published by CFA having an assigned 'high' fire hazard rating, the remaining MD is assigned 'low' fire hazard rating.

The CFA, on a four year cycle, reviews the Fire Hazard Ratings for Powerlines in all municipalities where the CAV has been assigned. The maps displays data for areas assigned 'low' fire hazard ratings only.

Viomap Digital Property and Viomap Digital Transport data sets on licence from Spatial Information Infrastructure, DSE. Overhead powerline and power pole data on licence from SP AusNet, PowerCor, UED and Jemena. No High Voltage and Low Voltage underground powerline as well as overhead transmission line data (in excess of 66kV) are displayed.

USERS ACCEPT THAT THEY HAVE READ AND FULLY UNDERSTOOD ALL ASSOCIATED COPYRIGHT AND DISCLAIMER STATEMENTS.

FIRE HAZARD RATINGS ARE CURRENT AS AT MAY 2013.

Legend

- Low Fire Hazard Ratings
- Undefined Fire Hazard Ratings
- Power Distribution Co. Boundary
- Local Government Areas (LGAs)
- Parcel / Property
- Powerpoles
- Low Voltage Powerlines
- High Voltage Powerlines
- Lakes
- Major Watercourses
- Freeway / Highway
- Main Roads

**FIRE HAZARD RATINGS
(THE ELECTRICITY SAFETY ACT 1998, REVISED 2010)**



Spatial Information Services

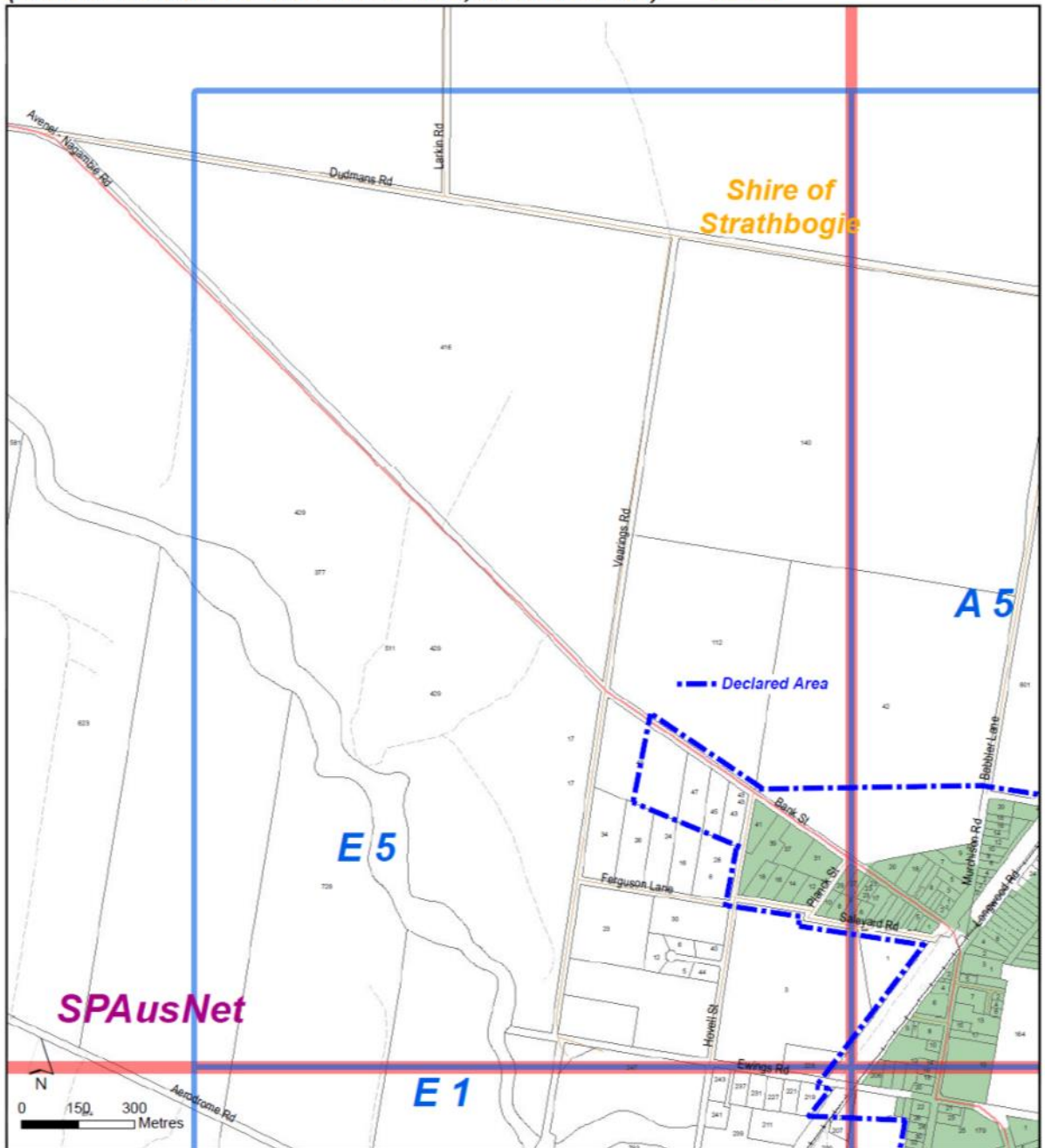

NAGAMBIE E 5 MAP 1:10 000

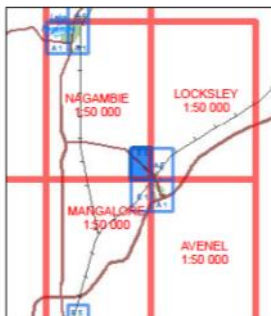

Fire Hazard Ratings assigned for Part 8 § 80 of the Electricity Safety Act 1998 (revised 2010) to the Country Area of Victoria (CAV) within the meaning of the Country Fire Authority Act 1958 and the Metropolitan District (MD) within the meaning of the Metropolitan Fire Brigades Act 1958.

PLEASE NOTE:

- The Department of Sustainability and Environment (DSE) has no collaboration with CFA during municipality reviews of Fire Hazard Ratings for Powerlines where the municipality contains both CAV and Public Land under the control of the Secretary of the DSE. Under the Forests Act 1958 they have NOT been assigned fire hazard ratings. The DSE assigns all Public Land to 'high' fire hazard rating.
- The MFB has collaborated with the CFA to review municipalities that share CAV and MD. Except for the parts that are public land under the control of the Secretary of the DSE & the parts specified in the maps published by CFA having an assigned 'high' fire hazard rating, the remaining MD is assigned 'low' fire hazard rating.

The CFA, on a four year cycle, reviews the Fire Hazard Ratings for Powerlines in all municipalities where the CAV has been assigned. The maps displays data for areas assigned 'low' fire hazard ratings only.

Vicmap Digital Property and Vicmap Digital Transport data sets on licence from Spatial Information Infrastructure. DSE, Overhead powerline and power pole data on licence from SP AusNet, PowerCor, UED and Jemena. No High Voltage and Low Voltage underground powerline as well as overhead transmission line data (in excess of 66kV) are displayed.

USERS ACCEPT THAT THEY HAVE READ AND FULLY UNDERSTOOD ALL ASSOCIATED COPYRIGHT AND DISCLAIMER STATEMENTS.

FIRE HAZARD RATINGS ARE CURRENT AS AT MAY 2013.

Legend	
	Low Fire Hazard Ratings
	Undefined Fire Hazard Ratings
	Power Distribution Co. Boundary
	Local Government Areas (LGAs)
	Parcel / Property
	Powerpoles
	Low Voltage Powerlines
	High Voltage Powerlines
	Lakes
	Major Watercourses
	Freeway / Highway
	Main Roads

**FIRE HAZARD RATINGS
(THE ELECTRICITY SAFETY ACT 1998, REVISED 2010)**



**Spatial Information
Services**

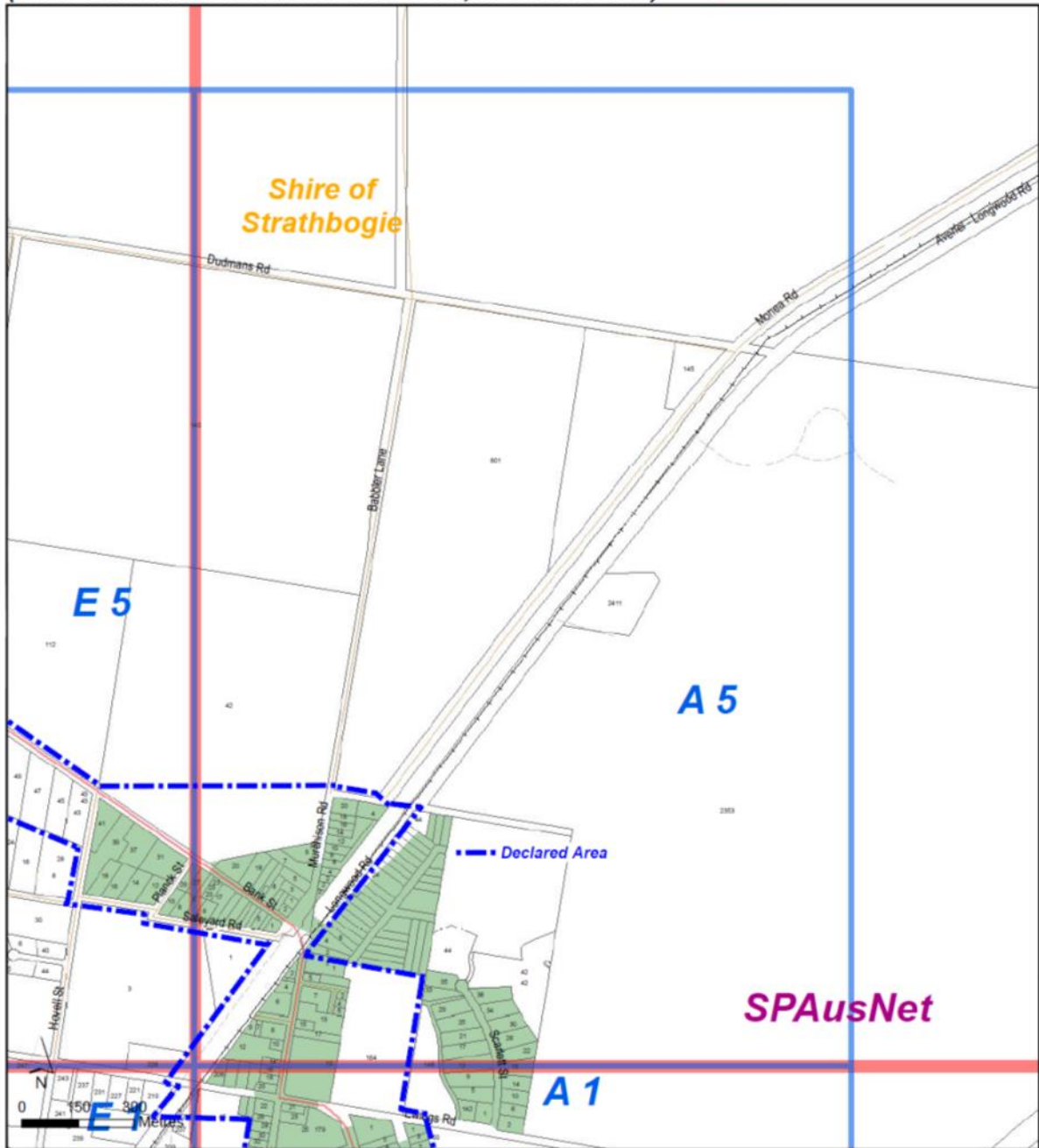

LOCKSLEY A 5 MAP 1:10 000



Fire Hazard Ratings assigned for Part 8 § 80 of the Electricity Safety Act 1998 (revised 2010) to the Country Area of Victoria (CAV) within the meaning of the Country Fire Authority Act 1958 and the Metropolitan District (MD) within the meaning of the Metropolitan Fire Brigades Act 1958.

PLEASE NOTE:

- The Department of Sustainability and Environment (DSE) has no collaboration with CFA during municipality reviews of Fire Hazard Ratings for Powerlines where the municipality contains both CAV and Public Land under the control of the Secretary of the DSE. Under the Forests Act 1958 they have NOT been assigned fire hazard ratings. The DSE assigns all Public Land to 'high' fire hazard rating.
- The MFB has collaborated with the CFA to review municipalities that share CAV and MD. Except for the parts that are public land under the control of the Secretary of the DSE & the parts specified in the maps published by CFA having an assigned 'high' fire hazard rating, the remaining MD is assigned 'low' fire hazard rating.

The CFA, on a four year cycle, reviews the Fire Hazard Ratings for Powerlines in all municipalities where the CAV has been assigned. The maps displays data for areas assigned 'low' fire hazard ratings only.

Viomap Digital Property and Viomap Digital Transport data sets on licence from Spatial Information Infrastructure, DSE. Overhead powerline and power pole data on licence from SP AusNet, PowerCor, UED and Jemena. No High Voltage and Low Voltage underground powerline as well as overhead transmission line data (in excess of 66kV) are displayed.

USERS ACCEPT THAT THEY HAVE READ AND FULLY UNDERSTOOD ALL ASSOCIATED COPYRIGHT AND DISCLAIMER STATEMENTS.

FIRE HAZARD RATINGS ARE CURRENT AS AT MAY 2013.

Legend

- Low Fire Hazard Ratings
- Undefined Fire Hazard Ratings
- Power Distribution Co. Boundary
- Local Government Areas (LGAs)
- Parcel / Property
- Powerpoles
- Low Voltage Powerlines
- High Voltage Powerlines
- Lakes
- Major Watercourses
- Freeway / Highway
- Main Roads

Appendix 2 – Declared Area and Fire Risk Maps - Euroa

Euroa Declared Area Map from Council's Asset Management System (Confirm)

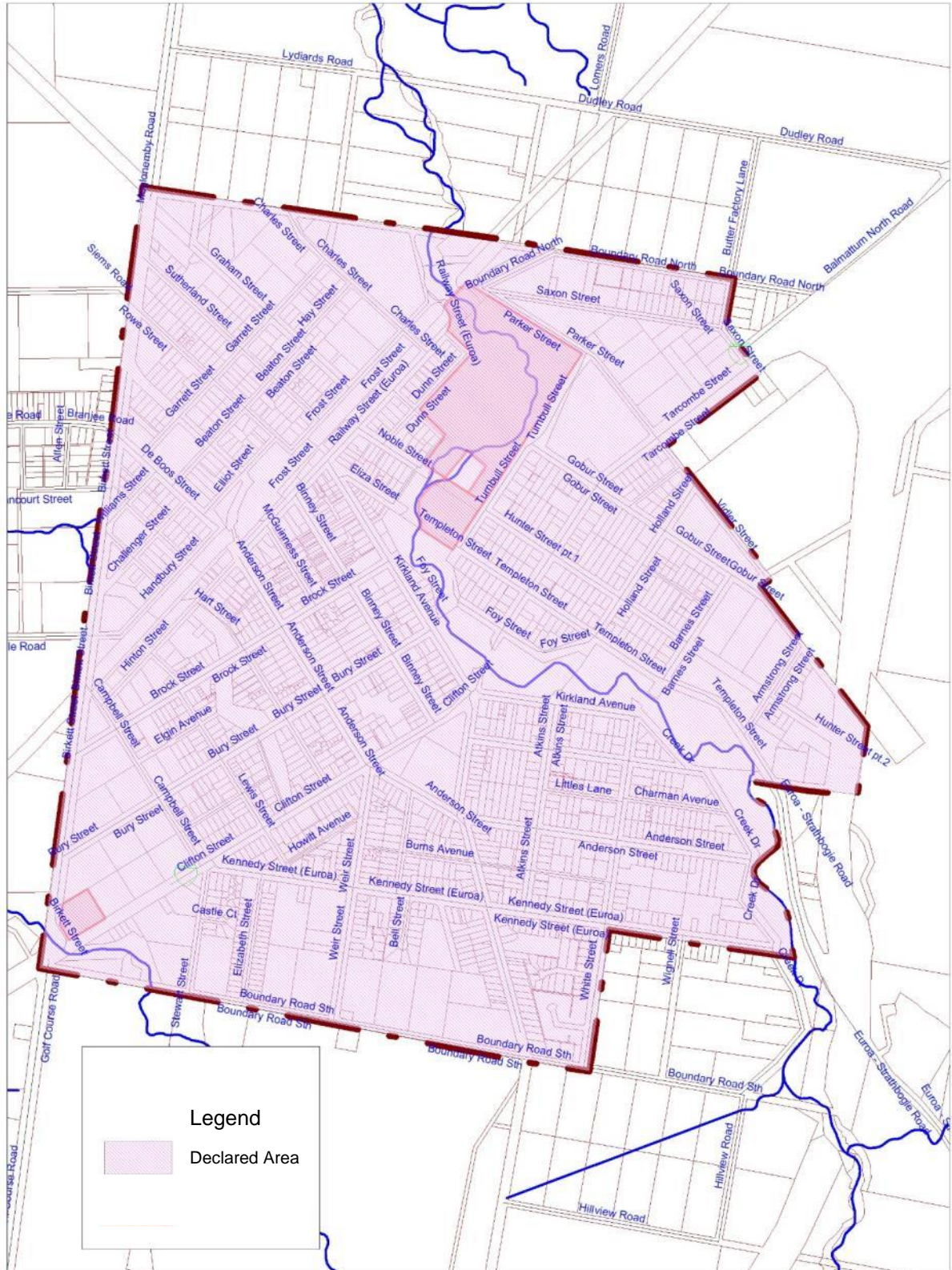

**FIRE HAZARD RATINGS
(THE ELECTRICITY SAFETY ACT 1998, REVISED 2010)**



Spatial Information Services

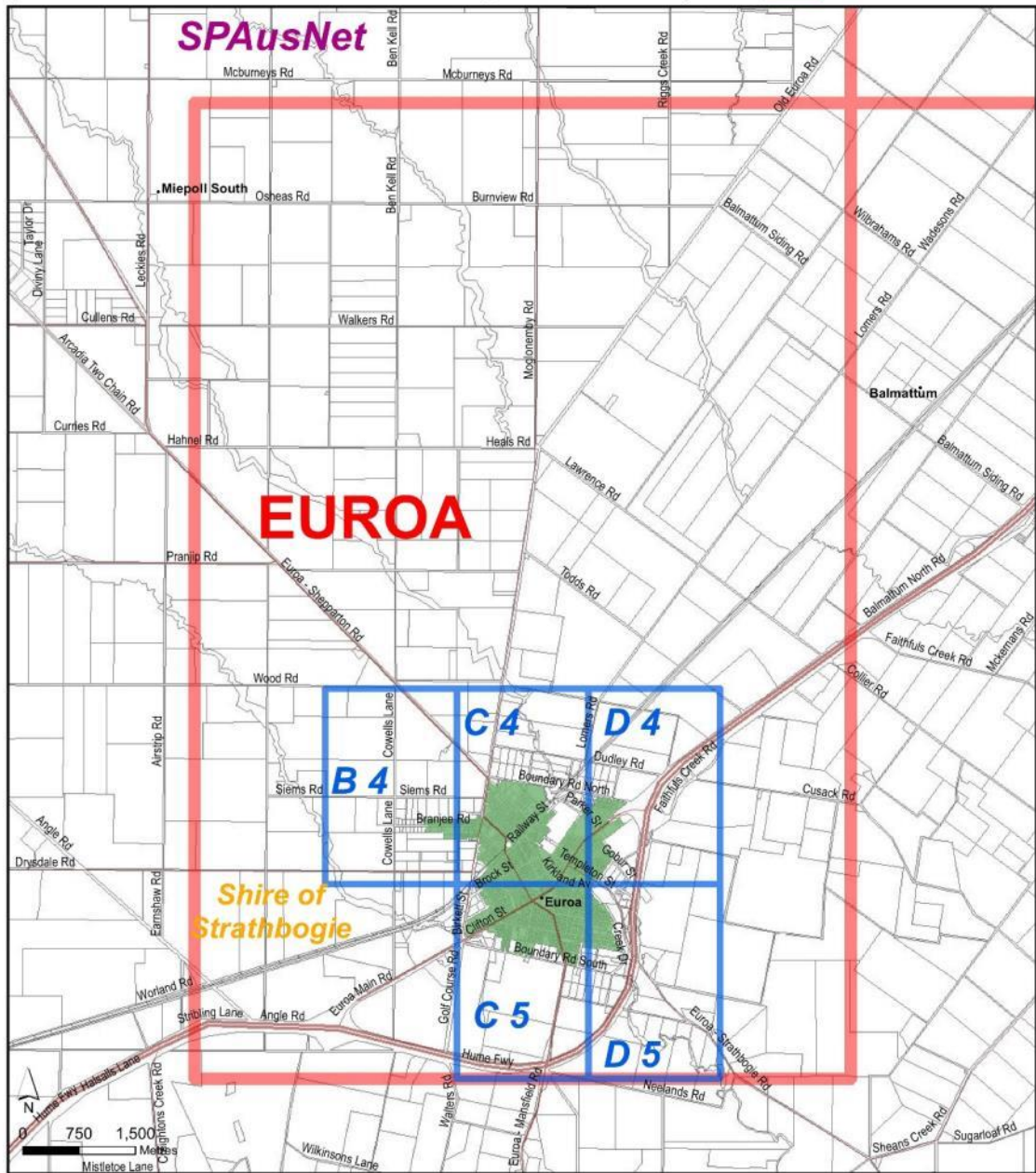

EUROA 1:50 000

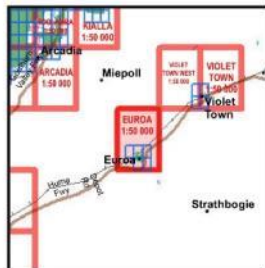

Fire Hazard Ratings assigned for Part 8 § 80 of the Electricity Safety Act 1998 (revised 2010) to the Country Area of Victoria (CAV) within the meaning of the Country Fire Authority Act 1998 and the Metropolitan District (MD) within the meaning of the Metropolitan Fire Brigades Act 1958.

PLEASE NOTE:

- The Department of Sustainability and Environment (DSE) has no collaboration with CFA during municipality reviews of Fire Hazard Ratings for Powerlines where the municipality contains both CAV and Public Land under the control of the Secretary of the DSE. Under the Forests Act 1998 they have NOT been assigned fire hazard ratings. The DSE assigns all Public Land to 'high' fire hazard rating.
- The MFB has collaborated with the CFA to review municipalities that share CAV and MD. Except for the parts that are public land under the control of the Secretary of the DSE & the parts specified in the maps published by CFA having an assigned 'high' fire hazard rating, the remaining MD is assigned 'low' fire hazard rating.

The CFA, on a four year cycle, reviews the Fire Hazard Ratings for Powerlines in all municipalities where the CAV has been assigned. The maps displays data for areas assigned 'low' fire hazard ratings only.

Vicmap Digital Property and Vicmap Digital Transport data sets on licence from Spatial Information Infrastructure, DSE. Overhead powerline and power pole data on licence from SP AusNet, PowerCor, UED and Jemena. No High Voltage and Low Voltage underground powerline as well as overhead transmission line data (in excess of 66kV) are displayed.

USERS ACCEPT THAT THEY HAVE READ AND FULLY UNDERSTOOD ALL ASSOCIATED COPYRIGHT AND DISCLAIMER STATEMENTS.

FIRE HAZARD RATINGS ARE CURRENT AS AT MAY 2013.

Legend

- Low Fire Hazard Ratings
- Undefined Fire Hazard Ratings
- Parcel / Property
- Power Distribution Co. Boundary
- Local Government Areas (LGAs)
- Lakes
- Major Watercourses
- Freeway / Highway
- Main Roads

**FIRE HAZARD RATINGS
(THE ELECTRICITY SAFETY ACT 1998, REVISED 2010)**



**Spatial Information
Services**

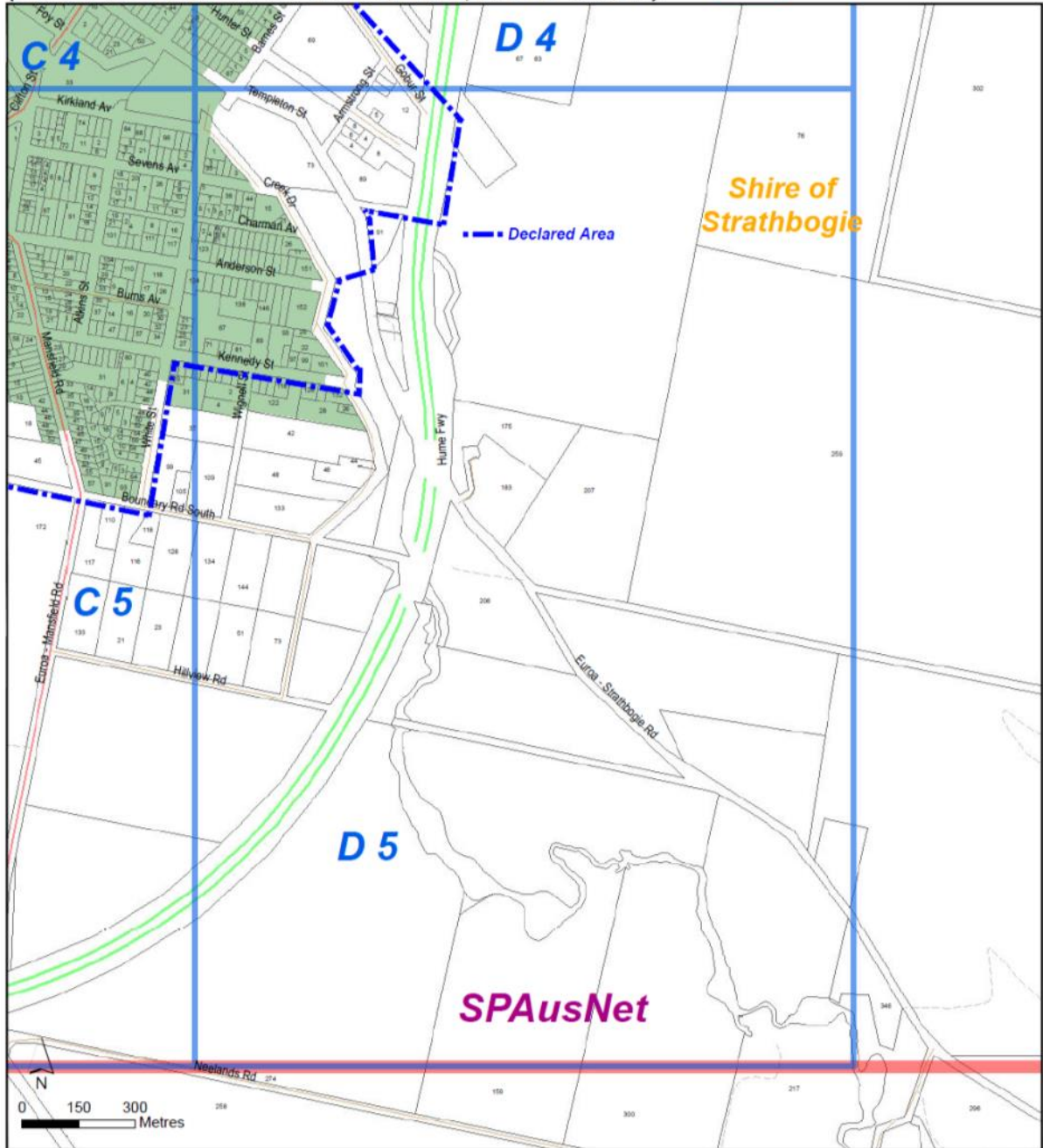

EUROA D 5 MAP 1:10 000

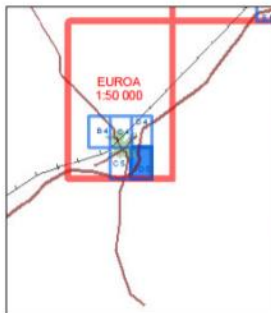

Fire Hazard Ratings assigned for Part 8 5 80 of the Electricity Safety Act 1998 (revised 2010) to the Country Area of Victoria (CAV) within the meaning of the Country Fire Authority Act 1958 and the Metropolitan District (MD) within the meaning of the Metropolitan Fire Brigades Act 1958.

PLEASE NOTE:

- The Department of Sustainability and Environment (DSE) has no collaboration with CFA during municipality reviews of Fire Hazard Ratings for Powerlines where the municipality contains both CAV and Public Land under the control of the Secretary of the DSE. Under the Forests Act 1958 they have NOT been assigned fire hazard ratings. The DSE assigns all Public Land to 'high' fire hazard rating.
- The MFB has collaborated with the CFA to review municipalities that share CAV and MD. Except for the parts that are public land under the control of the Secretary of the DSE & the parts specified in the maps published by CFA having an assigned 'high' fire hazard rating, the remaining MD is assigned 'low' fire hazard rating.

The CFA, on a four year cycle, reviews the Fire Hazard Ratings for Powerlines in all municipalities where the CAV has been assigned. The maps displays data for areas assigned 'low' fire hazard ratings only.

Viomap Digital Property and Viomap Digital Transport data sets on licence from Spatial Information Infrastructure, DSE. Overhead powerline and power pole data on licence from SP AusNet, PowerCor, UED and Jemena. No High Voltage and Low Voltage underground powerline as well as overhead transmission line data (in excess of 66kV) are displayed.

USERS ACCEPT THAT THEY HAVE READ AND FULLY UNDERSTOOD ALL ASSOCIATED COPYRIGHT AND DISCLAIMER STATEMENTS.

FIRE HAZARD RATINGS ARE CURRENT AS AT MAY 2013.

Legend

- Low Fire Hazard Ratings
- Undefined Fire Hazard Ratings
- Power Distribution Co. Boundary
- Local Government Areas (LGAs)
- Parcel / Property
- Powerpoles
- Low Voltage Powerlines
- High Voltage Powerlines
- Lakes
- Major Watercourses
- Freeway / Highway
- Main Roads

**FIRE HAZARD RATINGS
(THE ELECTRICITY SAFETY ACT 1998, REVISED 2010)**



**Spatial Information
Services**

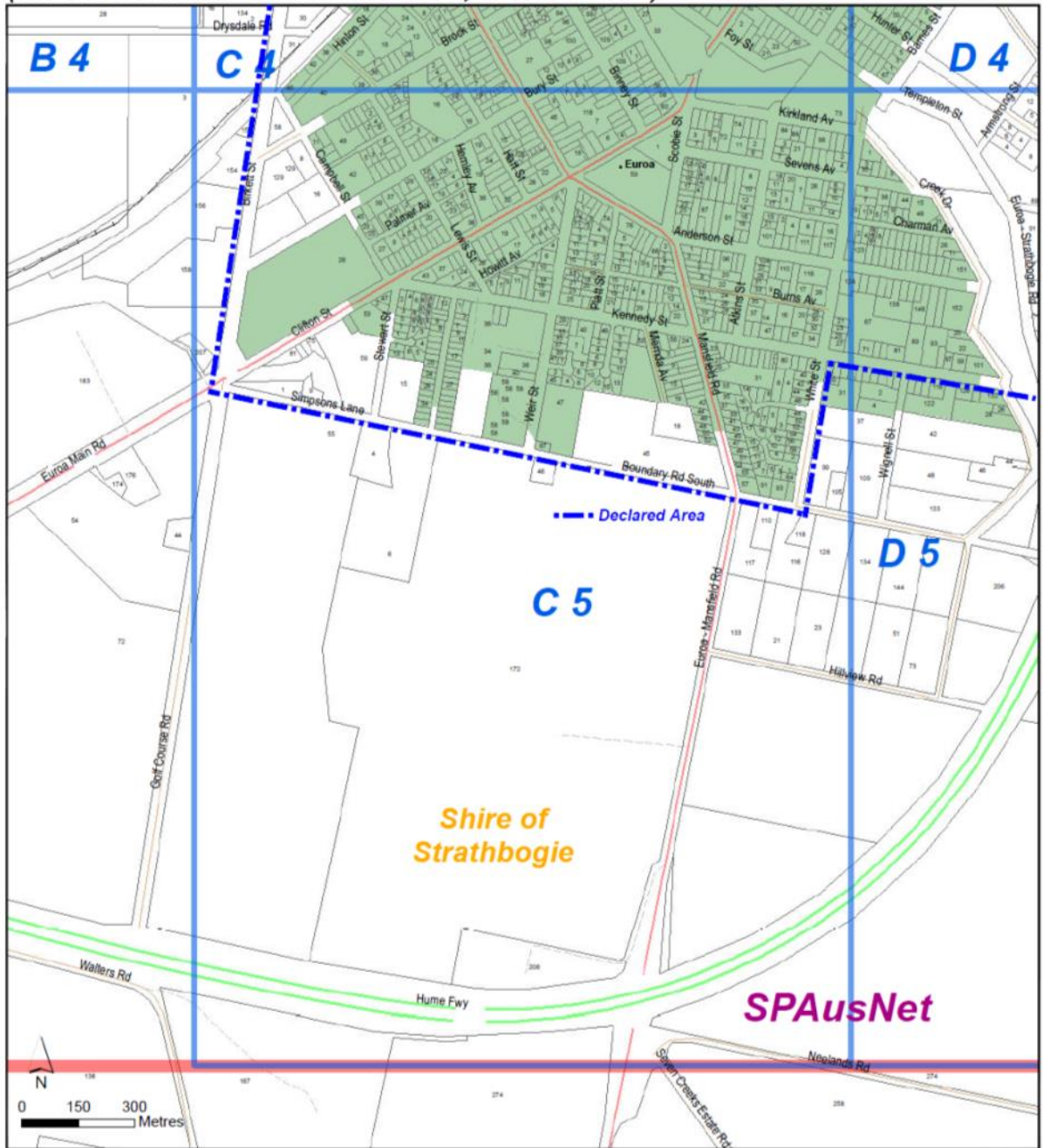

EUROA C 5 MAP 1:10 000

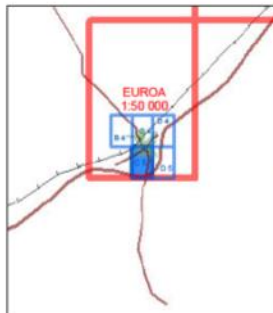

Fire Hazard Ratings assigned for Part 8 § 80 of the Electricity Safety Act 1998 (revised 2010) to the Country Area of Victoria (CAV) within the meaning of the Country Fire Authority Act 1958 and the Metropolitan District (MD) within the meaning of the Metropolitan Fire Brigades Act 1958.

PLEASE NOTE:

- The Department of Sustainability and Environment (DSE) has no collaboration with CFA during municipality reviews of Fire Hazard Ratings for Powerlines where the municipality contains both CAV and Public Land under the control of the Secretary of the DSE. Under the Forests Act 1958 they have NOT been assigned fire hazard ratings. The DSE assigns all Public Land to 'high' fire hazard rating.
- The MFB has collaborated with the CFA to review municipalities that share CAV and MD. Except for the parts that are public land under the control of the Secretary of the DSE & the parts specified in the maps published by CFA having an assigned 'high' fire hazard rating, the remaining MD is assigned 'low' fire hazard rating.

The CFA, on a four year cycle, reviews the Fire Hazard Ratings for Powerlines in all municipalities where the CAV has been assigned. The maps displays data for areas assigned 'low' fire hazard ratings only.

Viomap Digital Property and Viomap Digital Transport data sets on licence from Spatial Information Infrastructure, DSE. Overhead powerline and power pole data on licence from SP AusNet, PowerCor, UED and Jemena. No High Voltage and Low Voltage underground powerline as well as overhead transmission line data (in excess of 66kV) are displayed.

USERS ACCEPT THAT THEY HAVE READ AND FULLY UNDERSTOOD ALL ASSOCIATED COPYRIGHT AND DISCLAIMER STATEMENTS.

FIRE HAZARD RATINGS ARE CURRENT AS AT MAY 2013.

Legend

- Low Fire Hazard Ratings
- Undefined Fire Hazard Ratings
- Power Distribution Co. Boundary
- Local Government Areas (LGAs)
- Parcel / Property
- Powerpoles
- Low Voltage Powerlines
- High Voltage Powerlines
- Lakes
- Major Watercourses
- Freeway / Highway
- Main Roads

**FIRE HAZARD RATINGS
(THE ELECTRICITY SAFETY ACT 1998, REVISED 2010)**



**Spatial Information
Services**

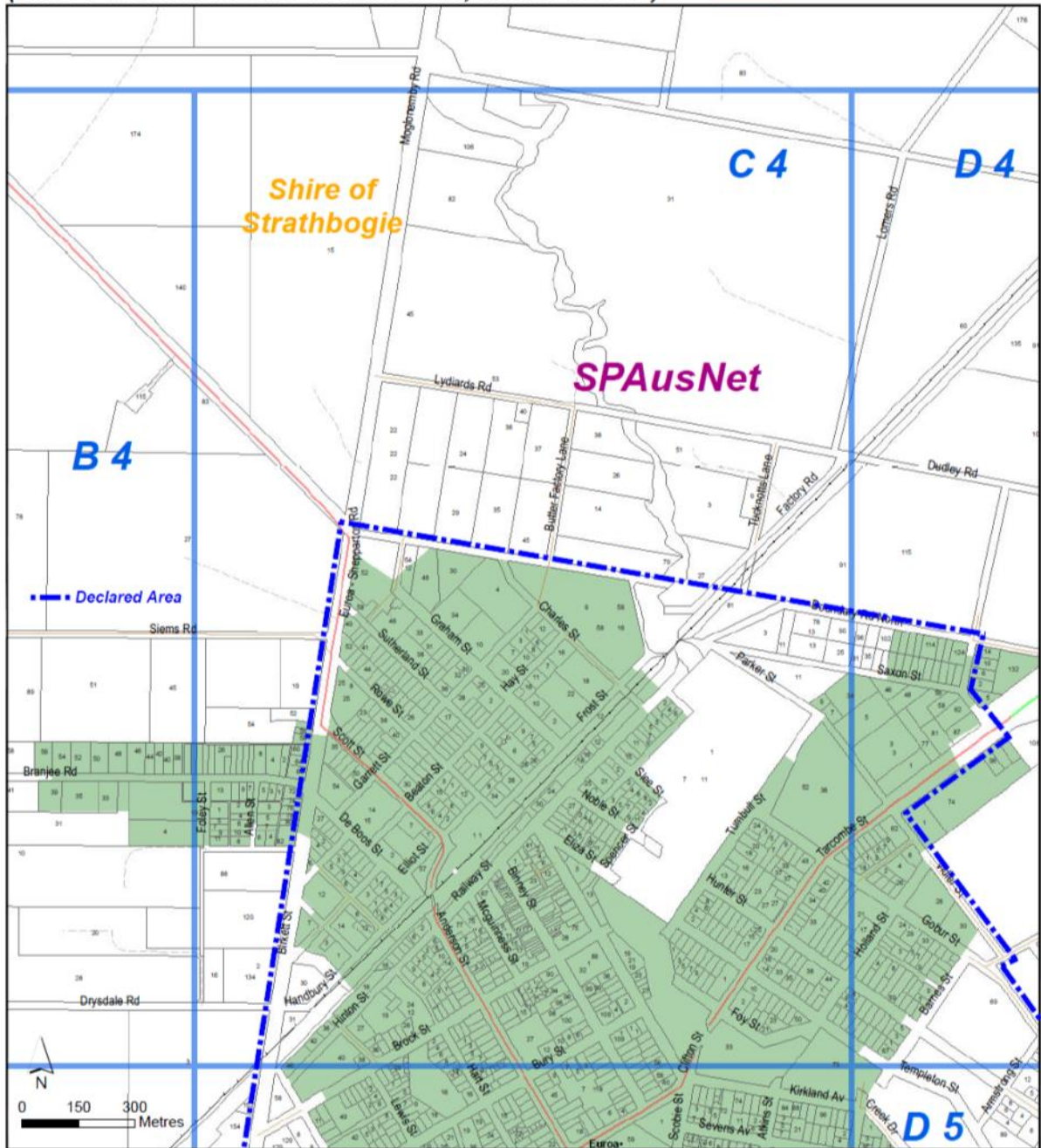

EUROA C 4 MAP 1:10 000



Fire Hazard Ratings assigned for Part 8 § 80 of the Electricity Safety Act 1998 (revised 2010) to the Country Area of Victoria (CAV) within the meaning of the Country Fire Authority Act 1958 and the Metropolitan District (MD) within the meaning of the Metropolitan Fire Brigades Act 1958.

PLEASE NOTE:

- The Department of Sustainability and Environment (DSE) has no collaboration with CFA during municipality reviews of Fire Hazard Ratings for Powerlines where the municipality contains both CAV and Public Land under the control of the Secretary of the DSE. Under the Forests Act 1958 they have NOT been assigned fire hazard ratings. The DSE assigns all Public Land to 'high' fire hazard rating.
- The MFB has collaborated with the CFA to review municipalities that share CAV and MD. Except for the parts that are public land under the control of the Secretary of the DSE & the parts specified in the maps published by CFA having an assigned 'high' fire hazard rating, the remaining MD is assigned 'low' fire hazard rating.

The CFA, on a four year cycle, reviews the Fire Hazard Ratings for Powerlines in all municipalities where the CAV has been assigned. The maps displays data for areas assigned 'low' fire hazard ratings only.

Viomap Digital Property and Viomap Digital Transport data sets on licence from Spatial Information Infrastructure, DSE. Overhead powerline and power pole data on licence from SP AusNet, PowerCor, UED and Jemena. No High Voltage and Low Voltage underground powerline as well as overhead transmission line data (in excess of 66kV) are displayed.

USERS ACCEPT THAT THEY HAVE READ AND FULLY UNDERSTOOD ALL ASSOCIATED COPYRIGHT AND DISCLAIMER STATEMENTS.

FIRE HAZARD RATINGS ARE CURRENT AS AT MAY 2013.

Legend

- Low Fire Hazard Ratings
- Undefined Fire Hazard Ratings
- Power Distribution Co. Boundary
- Local Government Areas (LGAs)
- Parcel / Property
- Powerpoles
- Low Voltage Powerlines
- High Voltage Powerlines
- Lakes
- Major Watercourses
- Freeway / Highway
- Main Roads

**FIRE HAZARD RATINGS
(THE ELECTRICITY SAFETY ACT 1998, REVISED 2010)**



**Spatial Information
Services**

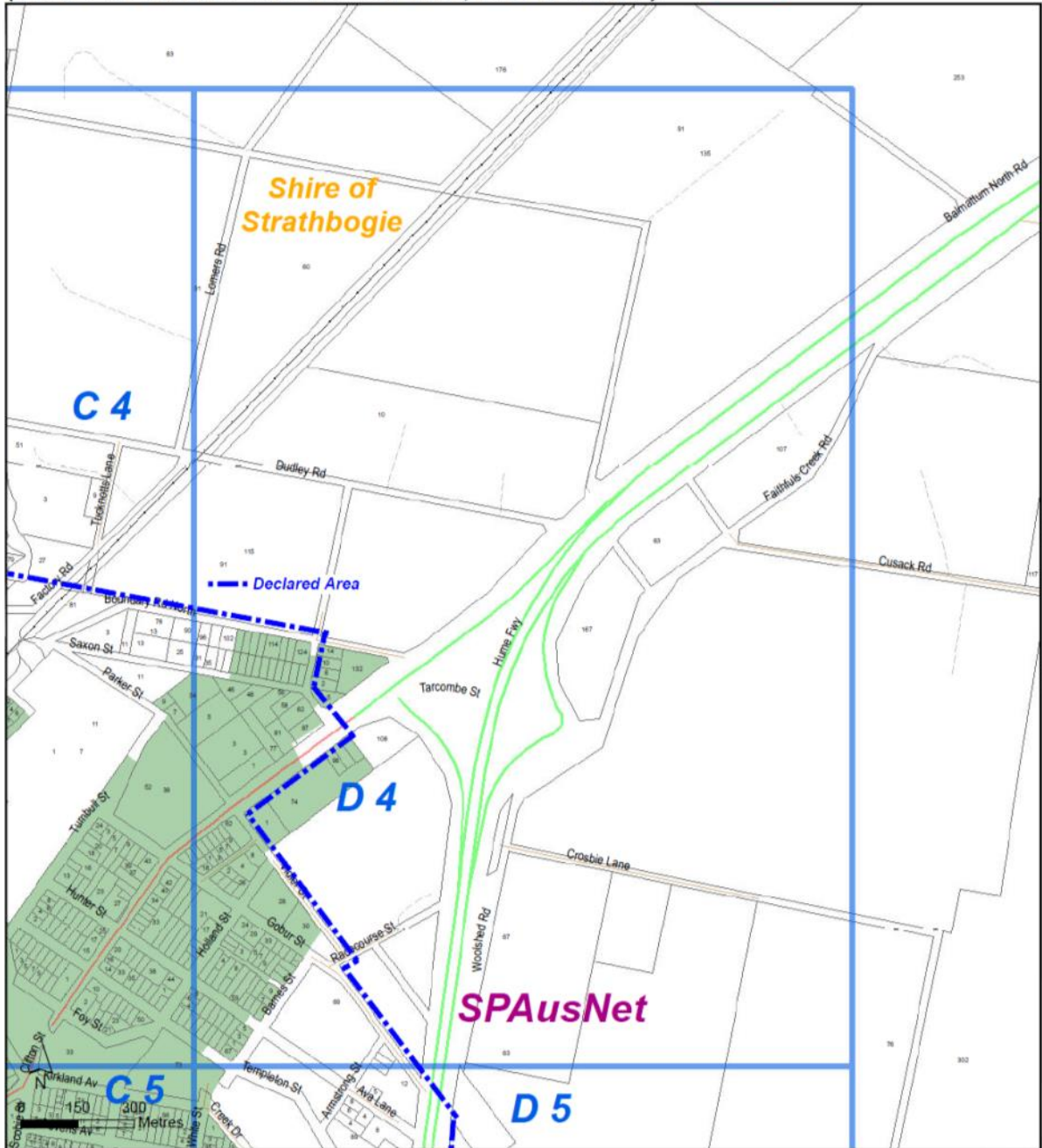

EUROA D 4 MAP 1:10 000



Fire Hazard Ratings assigned for Part 8 5 80 of the Electricity Safety Act 1998 (revised 2010) to the Country Area of Victoria (CAV) within the meaning of the Country Fire Authority Act 1958 and the Metropolitan District (MD) within the meaning of the Metropolitan Fire Brigades Act 1958.

PLEASE NOTE:

- The Department of Sustainability and Environment (DSE) has no collaboration with CFA during municipality reviews of Fire Hazard Ratings for Powerlines where the municipality contains both CAV and Public Land under the control of the Secretary of the DSE. Under the Forests Act 1958 they have NOT been assigned fire hazard ratings. The DSE assigns all Public Land to 'high' fire hazard rating.
- The MFB has collaborated with the CFA to review municipalities that share CAV and MD. Except for the parts that are public land under the control of the Secretary of the DSE & the parts specified in the maps published by CFA having an assigned 'high' fire hazard rating, the remaining MD is assigned 'low' fire hazard rating.

The CFA, on a four year cycle, reviews the Fire Hazard Ratings for Powerlines in all municipalities where the CAV has been assigned. The maps displays data for areas assigned 'low' fire hazard ratings only.

Viomap Digital Property and Viomap Digital Transport data sets on licence from Spatial Information Infrastructure, DSE. Overhead powerline and power pole data on licence from SP AusNet, PowerCor, UED and Jemena. No High Voltage and Low Voltage underground powerline as well as overhead transmission line data (in excess of 66kV) are displayed.

USERS ACCEPT THAT THEY HAVE READ AND FULLY UNDERSTOOD ALL ASSOCIATED COPYRIGHT AND DISCLAIMER STATEMENTS.

FIRE HAZARD RATINGS ARE CURRENT AS AT MAY 2013.

Legend

- Low Fire Hazard Ratings
- Undefined Fire Hazard Ratings
- Power Distribution Co. Boundary
- Local Government Areas (LGAs)
- Parcel / Property
- Powerpoles
- Low Voltage Powerlines
- High Voltage Powerlines
- Lakes
- Major Watercourses
- Freeway / Highway
- Main Roads

Appendix 3

Notice of Urgent Cutting or Removal of Tree from unexpected regrowth or other reasons as per Clause 6 (2) (a), (b), (c), (d).of the Electricity Safety (Electric Line Clearance) Regulations 2015

	<p>Strathbogrie Shire Council 109A Binney Street, Euroa (P.O. Box 177) 3666 Tel: 03 5795 0000 Toll Free: 1800 065 993 Web: www.strathbogrie.vic.gov.au</p>
<p style="text-align: center;">STRATHBOGRIE SHIRE COUNCIL</p> <p style="text-align: center;">NOTICE OF URGENT TREE CUTTING OR REMOVAL</p> <p>Dear Occupier /of _____ Street, _____, and/or affected person/s</p> <p>Under Clause 6 of the Electricity Safety (Electric Line Clearance) Regulations 2015, the tree adjacent your property has been deemed to require urgent cutting or removal. Authorised contractors:</p> <p><input type="checkbox"/> Have undertaken these works in accordance with the Regulations.</p> <hr/> <p>If you have any queries about the works undertaken, please contact the Works Superintendent Bob Foster on mobile 0438 348774.</p> <p style="text-align: center;">Thank you</p> <p>Bob Foster Works Superintendent _____ (Date)</p>	

Appendix 4

Sample inspection record form. Note: the information is input directly into a tablet and then downloaded into the database. The image below is a screenshot of a typical field assessment.

●●● Telstra 3G 1:17 pm 78%

[← Tasks](#) Condition Survey

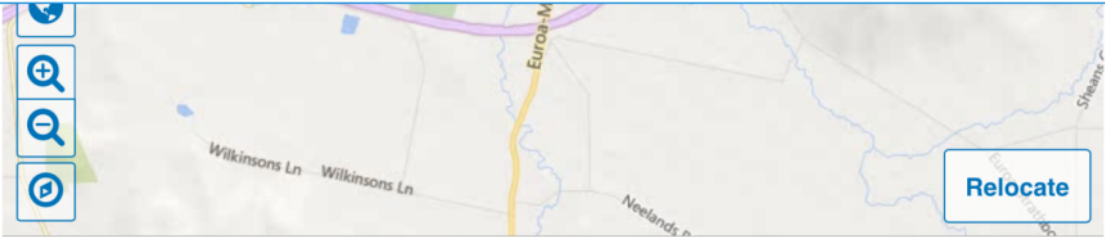

Anderson St, Euroa [8000027]

TR-Power Line Clearing EUROA

R00160/T/E01332

TR-Street Tree (TSTR)

Publicly Maintainable (01)

79 Anderson St

▶ Linked Documents

▼ Photo

▶ Defects

▼ Conditions

TR-Tree Requires Pruning Not Required (T603) ▼

▶ Defects

4. Liq. LV,HV. NWR

Save Draft

Complete

Appendix 5

Sample Screen Shot of Council's Asset Management System (Confirm).

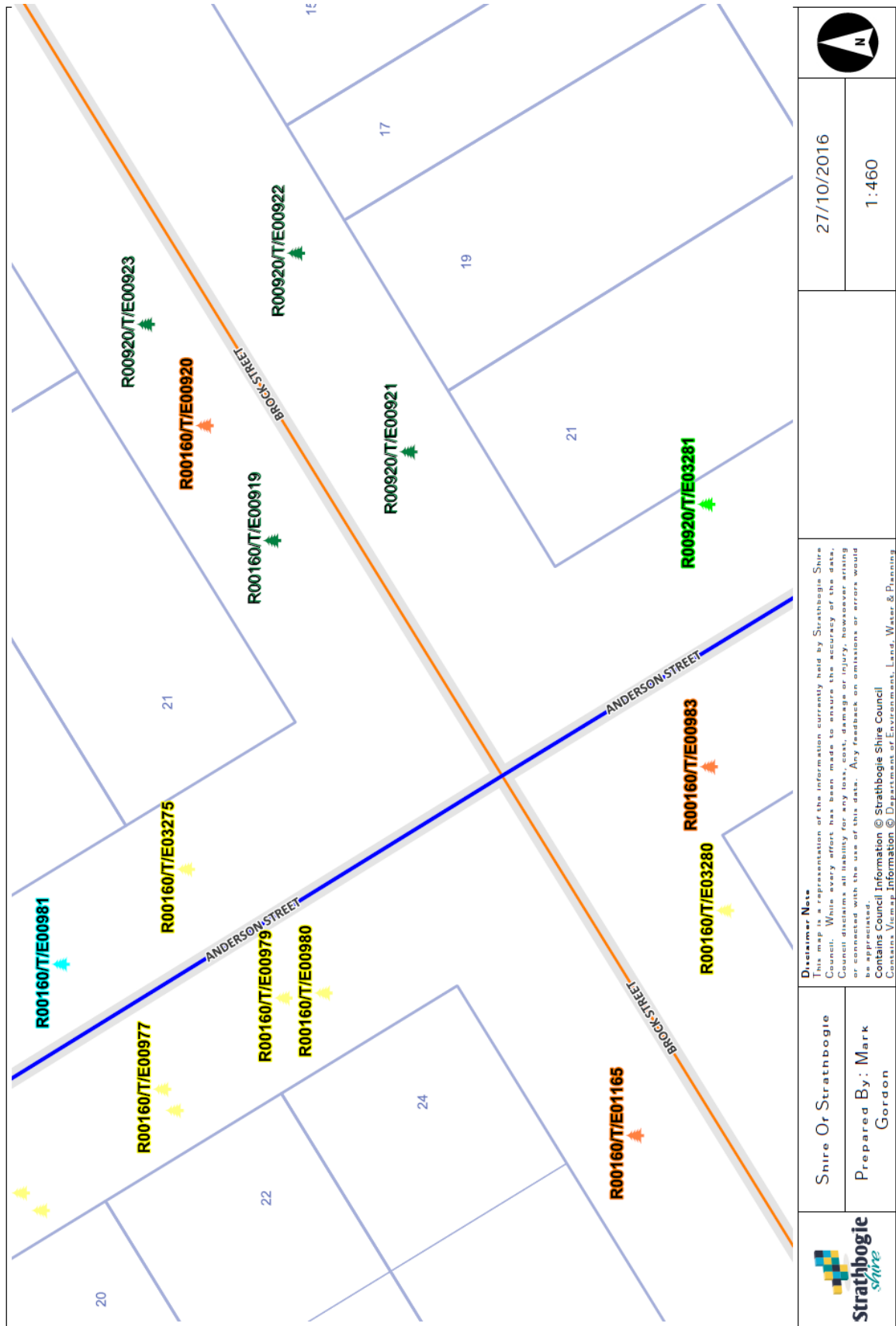

Appendix 6**Sample Publication to Clear Trees****PUBLIC NOTICE – NOTIFICATION OF TREE PRUNING**

Strathbogie Shire Council gives notice under the Electricity Safety (Electric Line Clearance) Regulations 2015 that it will be carrying out the pruning of trees around power lines in the townships of Avenel and Euroa commencing on or after 03rd October, 2018 approximately 1 month dependent on weather and other conditions.

The pruning works will be carried out as per Electricity Safety (Electric Line Clearance) Regulations 2015 and The Shire of Strathbogie Electric Line Clearance Vegetation Management Plan 2018/19.

Advertised in the Council Community Newsletter.

Appendix 7

Sample of Council's Tree Management System Works Instruction and Map Base showing the work location

•••• Telstra 3G 11:38 AM 48%

☰ Confirm ↻

List 25 Map Transfers

🔍 Filter tasks... Sort ▼

	Sevens Av, Euroa R09270/T/E01662 Trees - ELC Refer to Program - Annual Mtn - 5. Euc. LV. Remove Gum tree close to paddock fence. Poison stump. Ground crew. (Tw-Req... (64484) Work Committed	27 Aug 2017 13:34
	Sevens Av, Euroa R09270/T/E01663 Trees - ELC Refer to Program - Annual Mtn - 5. Fra. LV. Remove Ash tree growing within wire fence. Poison stump. Ground crew (T... (64485) Work Committed	27 Aug 2017 13:36
	Sevens Av, Euroa R09270/T/E01661 Trees - ELC Refer to Program - Annual Mtn - 5. Euc. LV. Remove lopped Gum tree and poison stump. No tag? Ground crew. Tree o... (64486) Work Committed	27 Aug 2017 13:39
	Anderson St, Euroa R00160/T/E01284 Trees - ELC Refer to Program - Annual Mtn - 5. Euc. LV. Remove tree and poison stump. Property owner Linda contacted and agre... (64511) Work Committed	29 Aug 2017 08:05
	Anderson St, Euroa R00160/T/E01285 Trees - ELC Refer to Program - Annual Mtn - 5. Euc. LV. Remove tree and poison stump. Property owner Linda contacted and agreed to re... (64512) Work Committed	29 Aug 2017 08:08
	Kennedy St, Euroa R06180/T/E01552 Trees - ELC Refer to Program - Annual Mtn - 5. Aca. Sw. Reduce side growth of wattle. (Tw-Requires Cyclic Pruning/PLC) (64520) Work Committed	29 Aug 2017 08:46
	Kennedy St, Euroa R06180/T/E01501 Trees - ELC Refer to Program - Annual Mtn - 5. Melia. SW. Reduce upright leader of branch over road. (Tw-Requires Cyclic Pruning... (64535) Work Committed	29 Aug 2017 10:20
	White St, Euroa R10490/T/E01392 Trees - ELC Refer to Program - Annual Mtn - 5. Fra. LV remove Ash tree on paddock fence line. Poison stump and list for grubbing. ... (64543) Work Committed	29 Aug 2017 11:07
	White St, Euroa R10490/T/E01390 Trees - ELC Refer to Program - Annual Mtn - 5. Fra. LV. Remove Ash tree and poison stump .List stump for grubbing. Ground crew.... (64544) Work Committed	29 Aug 2017 11:09
	Kennedy St, Euroa R06180/T/E01595 Trees - ELC Refer to Program - Annual Mtn - 5. Fra. LV. Remove semi mature Ash tree and poison stump . Tree on fence of paddoc... (64547) Work Committed	29 Aug 2017 11:22
	Anderson St, Euroa R00160/T/E01596 Trees - ELC Refer to Program - Annual Mtn - 5. Fra. LV. Remove Ash tree and poison stump . List stump for grubbing. Ground crew	

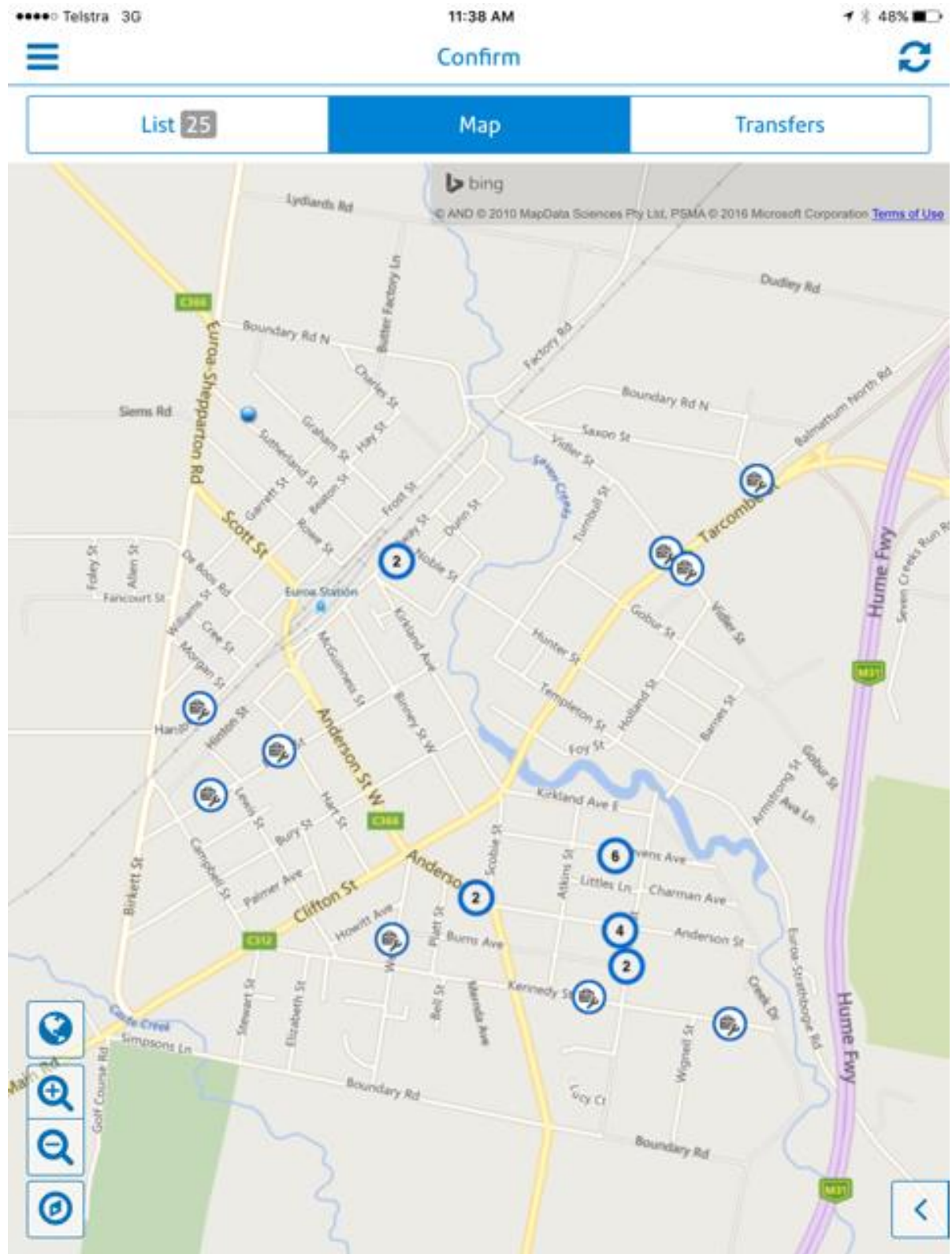

Appendix 8

Strathbogie Shire's Tree Maintenance Management Process

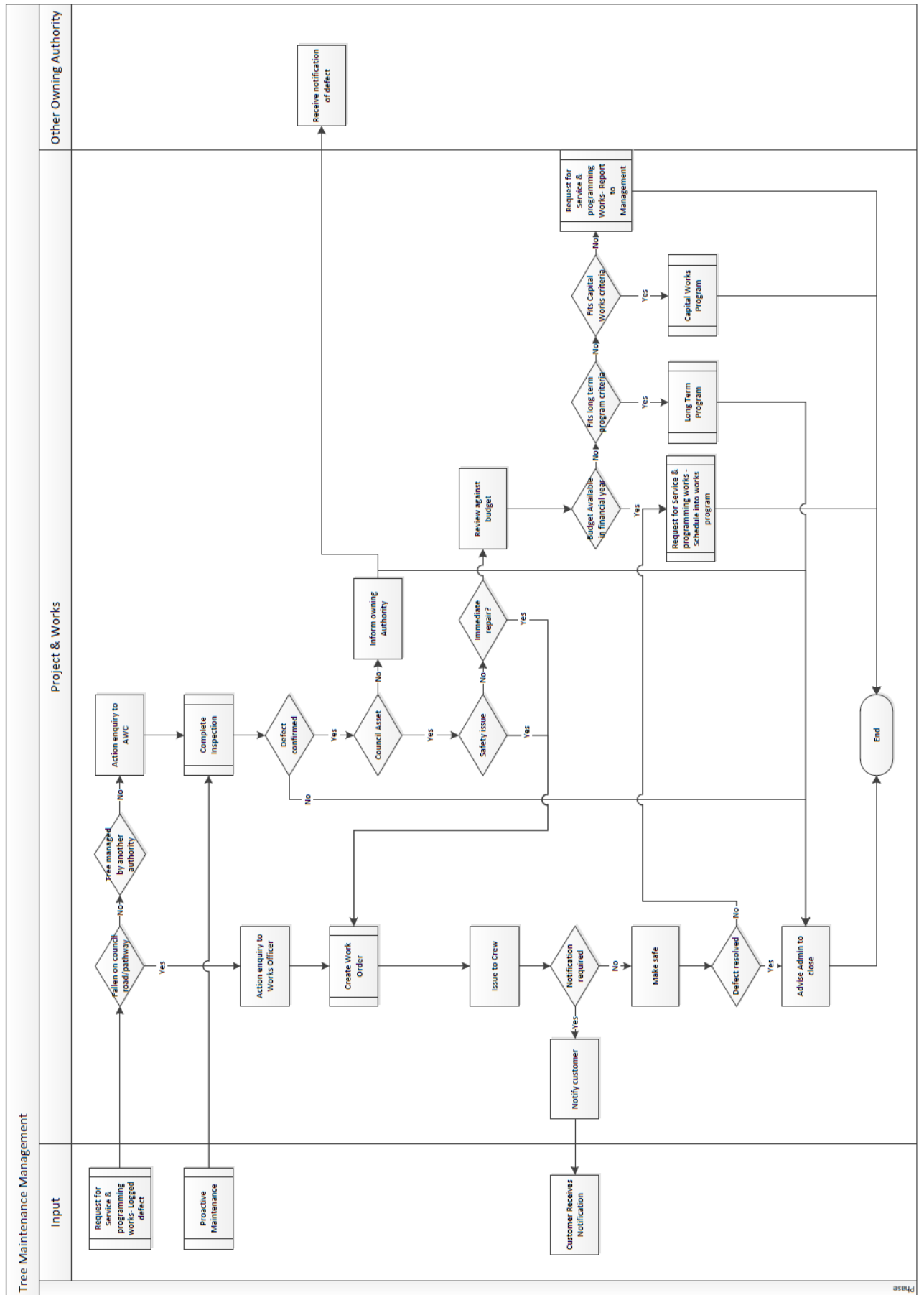

Appendix 9

Sample of the General Conditions of Contract AS2124-1992 – Table of Contents

AS 2124—1992

with
AS 2125—1992
AS 2127—1992

Australian Standard®

**General conditions of contract
(AS 2124—1992)**

together with

**General conditions of tendering and form of
tender (AS 2125—1992)**

**Form of formal instrument of agreement
(AS 2127—1992)**



OF QUANTITIES	7
ILITY, RETENTION MONEYS AND PERFORMANCE UNDERTAKINGS	8
NCE OF CONTRACT	10
CE OF NOTICES	11
RACT DOCUMENTS	11
NMENT AND SUBCONTRACTING	12
TED AND NOMINATED SUBCONTRACTORS	13
SIONAL SUMS	15
NT CONDITIONS	15
NTS, COPYRIGHT AND OTHER INTELLECTUAL PROPERTY RIGHTS	16
JTORY REQUIREMENTS	16
ECTION OF PEOPLE AND PROPERTY	17
OF THE WORK AND REINSTATEMENT OF DAMAGE	17
GE TO PERSONS AND PROPERTY OTHER THAN THE WORKS ...	18
ANCE OF THE WORKS	19
C LIABILITY INSURANCE	19
ANCE OF EMPLOYEES	20
CTION AND PROVISIONS OF INSURANCE POLICIES	20
K OF WORKS AND INSPECTORS	21
INTENDENT	21
INTENDENT'S REPRESENTATIVE	21
RACTOR'S REPRESENTATIVE	22
ROL OF CONTRACTOR'S EMPLOYEES AND SUBCONTRACTORS .	22
.....	22
NG OUT THE WORKS	23
.RIALS, LABOUR AND CONSTRUCTIONAL PLANT	23
.RIALS AND WORK	24
INATION AND TESTING	25
ING HOURS	26
RESS AND PROGRAMMING OF THE WORKS	26
ENSION OF THE WORKS	27
S FOR COMMENCEMENT AND PRACTICAL COMPLETION	27
.Y OR DISRUPTION COSTS	30
CTS LIABILITY	30
NING UP	30
INT PROTECTION	31
ATIONS	31
WORK	32
IFICATES AND PAYMENTS	33
EMENT OF WORKERS AND SUBCONTRACTORS	35
.ULT OR INSOLVENCY	36
INATION BY FRUSTRATION	39

the direction shall not be disputed unless a notice of dispute in accordance with Clause 47.1 is given by one party to the other party and to the Superintendent within 14 days after the date of service on that party of the notice pursuant to Clause 46.2(1).

47 DISPUTE RESOLUTION

47.1 Notice of Dispute

If a dispute between the Contractor and the Principal arises out of or in connection with the Contract, including a dispute concerning a direction given by the Superintendent, either party shall deliver by hand or send by certified mail to the other party and to the Superintendent a notice of dispute in writing adequately identifying and proving the dispute.

Notwithstanding the existence of a dispute, the Principal and the Contractor shall continue to perform the Contract, and subject to Clause 44, the Contractor shall continue to work under the Contract and the Principal and the Contractor shall continue to comply with Clause 42.1.

A claim in tort, under statute or for restitution based on unjust enrichment, rectification or frustration, may be included in an arbitration.

47.2 Further Steps Required Before Proceedings

Alternative 1

Within 14 days after service of a notice of dispute, the parties shall confer and at the option of either party and provided the Superintendent is present in the presence of the Superintendent, to attempt to resolve the dispute and failing that, the parties shall explore and if possible agree on methods of resolving the dispute by other means. At any such conference each party shall be represented by a person with authority to agree to a resolution of the dispute.

In the event that the dispute cannot be so resolved or if at any time either party considers that the other party is not making reasonable efforts to resolve the dispute, either party may by notice in writing delivered by hand or sent by certified mail to the other party refer such dispute to arbitration or litigation.

Alternative 2

A party served with a notice of dispute may give a written response to the other party and the Superintendent within 28 days of the receipt of the notice. Within 42 days of the service on the Superintendent of a notice of dispute, and within 14 days of the receipt by the Superintendent of the written response, or earlier, the Superintendent shall give to each party the Superintendent's written decision on the dispute, together with reasons for the decision.

If either party is dissatisfied with the decision of the Superintendent or if the Superintendent fails to give a written decision on the dispute within the time specified under Clause 47.2 the parties shall, within 14 days of the date of receipt of the decision or within 14 days of the date upon which the decision should have been given, confer and at least once attempt to resolve the dispute and failing that, the parties shall explore and if possible agree on methods of resolving the dispute by other means. At any such conference, each party shall be represented by a person with authority to agree to a resolution of the dispute.

In the event that the dispute cannot be so resolved or if at any time either party considers that the other party is not making reasonable efforts to resolve the dispute, either party may, by notice in writing delivered by hand or sent by certified mail to the other party, refer such dispute to arbitration or litigation.